



# Wattstopper®

Ultrasonic Line Voltage Occupancy Sensor with Light Level (v3)

No: 24778 – 06/20 rev. 3

Installation Instructions • Instructions d'Installation • Instrucciones de Instalación

## Catalog Number • Numéro de Catalogue • Número de Catálogo: UT-355

Country of Origin: Made in China • Pays d'origine: Fabriqué en Chine • País de origen: Hecho en China



### DESCRIPTION AND OPERATION

The Wattstopper UT-355 360° ultrasonic occupancy sensors operate on 120VAC, 230VAC (1Ø), 277VAC, or 347VAC. The UT-355 turns lighting systems on and off based on occupancy.

The sensors can be configured to turn lighting on, and hold it on as long as it detects occupancy. After no movement is detected for the user specified time (30 seconds to 30 minutes) the lights are switched off. A "walk-through" mode can turn lights off after only 3 minutes, if no activity is detected after 30 seconds of an occupancy detection.

### COVERAGE PATTERN

The UT-355 is available in 3 models. Each model has a different size coverage pattern. The coverage shown represents walking motion at a mounting height of 8 to 10 feet. For building spaces with lower levels of activity or with obstacles and barriers, coverage size may decrease.

### PLACEMENT GUIDELINES

Depending upon obstacles such as furniture or partitions, the area of coverage may be less or more than the sensing distances shown in the coverage pattern. This must be considered when planning the number of sensors and their placement. It is also recommended to place the sensor 4 to 6 feet away from air supply ducts. Mount the sensor to the ceiling. The UT-355 is designed for a ceiling height of about 8-10 feet. Mounting above or below this range will significantly affect the coverage patterns. As a general rule, each occupant should be able to clearly view the sensor.

**Open Office Area Coverage:** To get complete coverage in an open office area, install multiple sensors so that there is approximately 20% overlap with each adjacent sensor's ultrasonic coverage area.

### SPECIFICATIONS

Voltages.....	120//230/277/347VAC, 50/60Hz
Load Ratings	
@120VAC .....	0-800W Ballast/Tungsten/LED
@230VAC (Single Phase) .....	0-1200W
Ballast/LED	
@277VAC .....	0-1200W Ballast/LED
@347VAC .....	0-1500W Ballast/LED
Operating Temperature .....	32° to 131°F (0° to 55°C)
Light Level One-Step Adjustment.....	10FC - 300FC
Time Delay Adjustment .....	30 seconds to 30 minutes
Walk-Through Mode .....	3 minutes if no activity after 30 sec.
Test Mode .....	5 sec. upon DIP Switch reset
Ultrasonic Coverage	
Model UT-355-1 .....	up to 500 ft²
Model UT-355-2 .....	up to 1000 ft²
Model UT-355-3 .....	up to 2000 ft²
Sensitivity Adjustment.....	Minimum to Maximum (trimpot)
Frequency .....	40kHz
U.S. Patents: 7,277,012	

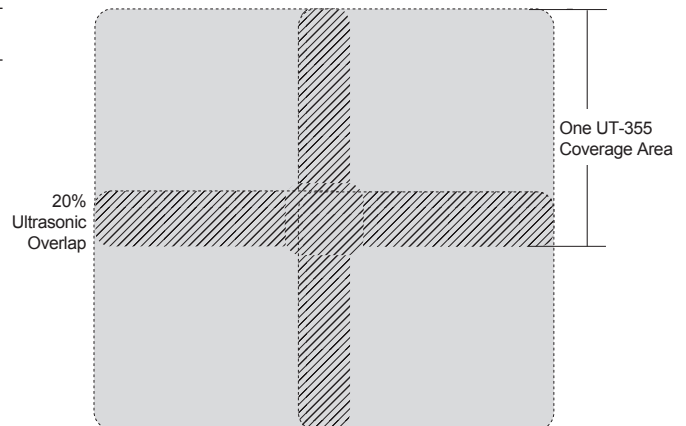
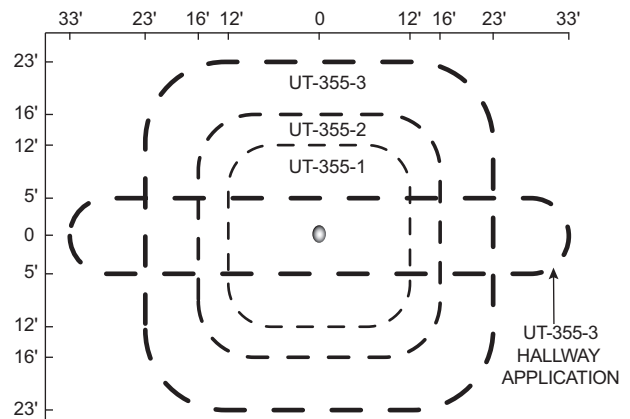

## WIRING DIRECTIONS



**WARNING: DO NOT INSTALL THE SENSOR IN A SPACE CONTROLLING A TOTAL LOAD THAT IS HIGHER THAN THE RATING OF THE DEVICE. EACH SENSOR WILL NEED TO SWITCH THE ENTIRE LOAD EVEN IF ADDITIONAL SENSORS ARE INSTALLED. RISK OF OVERLOAD, PRODUCT DAMAGE, SMOKE AND/OR FIRE MAY RESULT.**



**WARNING: TURN THE POWER OFF AT THE CIRCUIT BREAKER BEFORE INSTALLING SENSORS.**



### Multiple Sensors Connected in Parallel

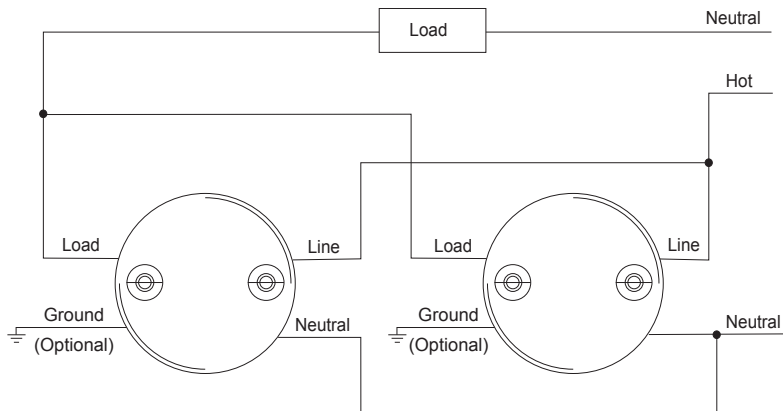

**NOTE:** This application does not allow for Load to increase

### Single Sensor, Single Load

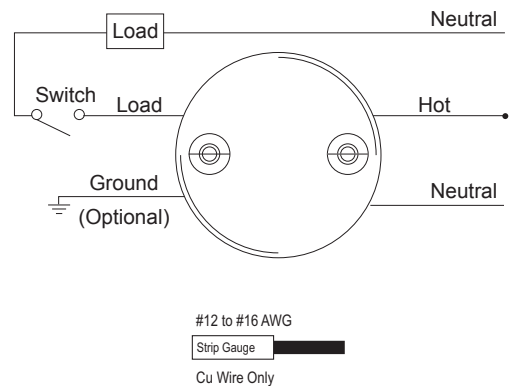

## MOUNTING THE SENSOR

### Using a 4-Inch Square Junction Box with Double-Gang Mudring

1. Pull the high voltage wires into the J-Box through the conduit knockout.
2. Connect the high voltage wires to the appropriate terminals on the sensor.
3. Align the sensor in the J-Box so that the mudring mounting screw tabs on the box match the mudring mounting holes on the sensor's rear housing.
4. Use two machine screws (included with the sensor) to attach the sensor to the mounting tabs on the J-Box.
5. Snap the front cover onto the sensor.

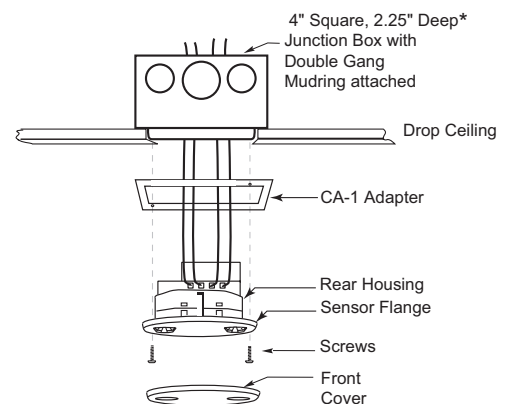

### Mounting to a 4" Square Junction Box with Mudring

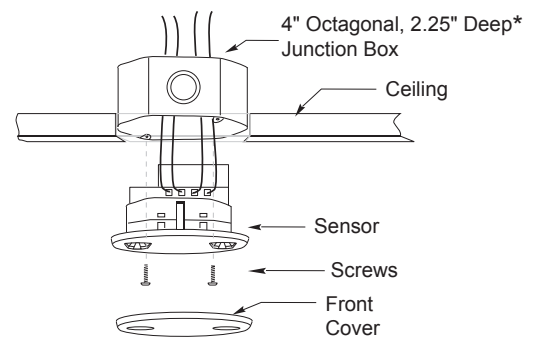

### Mounting to an Octagonal Junction Box

### Using an Octagonal J-Box

1. Pull the high voltage wires into the J-Box through the conduit knockout.
2. Connect the high voltage wires to the appropriate terminals on the sensor.
3. Align the sensor in the J-Box so that the mounting screw tabs on the box match the key holes on the sensor's rear housing.
4. Use two machine screws (included with the J-Box) to attach the sensor to the mounting tabs on the J-Box.
5. Snap the front cover onto the sensor.

**\*The Junction Box must be at least 2.25" deep. If it is not, an extension ring is required.**

## SENSOR ADJUSTMENT

**NOTE:** This unit is pre-set for basic operation as described in this guide. Adjustment is optional.

The sensors are factory preset to allow for quick installation in most applications. Verification of proper wiring or coverage, or customizing the sensor's settings can be done using the following procedures. To make adjustments, open the Front Cover with a small screwdriver.

Before making adjustments, make sure the office furniture is installed, lighting circuits are turned on, and the HVAC systems are in the overridden/on position. VAV systems should be set to their highest airflow. Set the Time Delay to the desired settings. See "DIP Switch Setting".

## To Test Occupancy Sensors

1. Ensure the Time Delay is set for **Test Mode\*** using the “Test Mode/20 minutes” setting (DIP Switches 1,2 & 3 are **OFF**).
2. Ensure that the Ultrasonic Sensitivity trimpot is set to about 70%, clockwise.
3. Ensure that the Light Level is at default (maximum). See the Light Level Feature section of this document for instructions.
4. Remain still. The green LED should not flash. The lights should turn off after 5 seconds. (If not, see “Troubleshooting.”)
5. Move about the coverage area. The lights should come **ON**. Adjust the Ultrasonic Sensitivity as necessary to provide the desired coverage (Green LED indicates activation from the ultrasonic sensor).

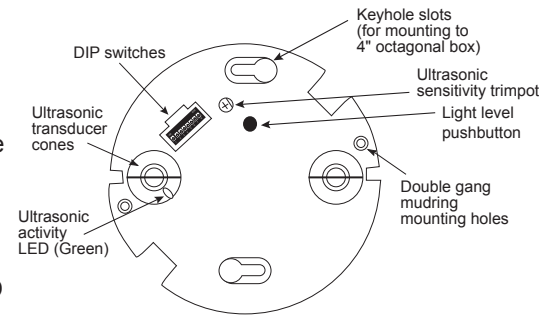

When testing and adjustment is complete, reset DIP Switches to the desired settings, and replace the cover on the sensor.

\*Test Mode is a temporary state that starts when you first set the sensor’s DIP Switches for the “Test Mode/20 minutes” (Switches 1, 2, 3 **OFF**). If you need to invoke the Test Mode and the DIP Switches are already set for Test Mode/20 minutes, toggle DIP Switch 1 **ON**, then back to the **OFF** position. This provides a 10 minute test period. During the test period, the Time Delay is only 5 seconds.

## DIP SWITCH SETTING

The UT-355 has 5 DIP Switches under the cover.

### Time Delay: Switches 1, 2, 3

The sensor will hold the lights **ON** as long as occupancy is detected. The time delay countdown starts when no motion is detected. After no motion is detected for the length of the time delay, the sensor will turn the lights **OFF**.

### Walk Through: Switch 4

Walk-through mode turns the lights **OFF** three minutes after the area is initially occupied, if no motion is detected after the first 30 seconds. If motion continues beyond the first 30 seconds, the selected time delay applies.

### Service: Switch 5

To override all sensor functions, set DIP Switch 5 to the **ON** position. The green LED will come on and stay on for the duration of the override. This bypasses the light level and occupancy detection control functions of the sensor.

Feature	Switch#
<b>Time Delay</b>	<b>1 2 3</b>
Test Mode/20 min	↓ ↓ ↓
30 seconds	↓ ↓ ↓
5 minutes	↓ ↑ ↓
10 minutes	↓ ↑ ↑
15 minutes	↑ ↓ ↓
20 minutes	↑ ↓ ↑
25 minutes	↑ ↑ ↓
30 minutes	↑ ↑ ↑
<b>Walk-Through</b>	<b>4</b>
Enabled	↑
Disabled	↓ ◀
<b>Service</b>	<b>5</b>
Service	↑
Normal	↓ ◀

◀ = Factory Setting  
 ↑ = ON  
 ↓ = OFF

## LIGHT LEVEL FEATURE

The Light Level feature holds lights off upon initial occupancy if adequate ambient light exists. It will not turn the lights **OFF** if they are **ON**. The default setting is for maximum, meaning that even the brightest ambient light will not hold the lights **OFF**.

### Notes on Functionality

- Avoid mounting the sensor close to lighting fixtures.
- Adjust during daylight hours when ambient light in the area is at desired level.
- Light Level cannot be enabled while Test Mode is active. Either wait for Test Mode to expire or select any of the other Time Delay settings before enabling the Light Level feature.
- The ultrasonic occupancy indicator LED is disabled when the Light Level feature is enabled. LED will also flash periodically to indicate the sensor has Light Level enabled.
- Light Level settings are only saved in the event of a power loss. Disabling Light Level and then reenabling it will not return it to previous settings.
- If Test Mode is enabled after Light Level has been set, Light Level functionality will cease to function throughout the duration of Test Mode. When Test Mode period expires, the Light Level functionality will resume, even if the Dip Switches remain set to Test Mode.

### Setting Light Level

1. Make sure Test Mode is not active.
2. Toggle the state of the sensor, by briefly pressing the Light Level button, to include or exclude the lighting load from the light level calibration.
3. Open the Front Cover and locate the Light Level pushbutton. See Sensor Adjustment.
4. Press and hold the Light Level button between 2s and 5s. The green LED will be **ON** showing 2s is reached and then be **OFF** showing 5s has passed.\* The sensor enters setup mode, as indicated by the rapidly flashing LED. The LED will flash throughout the setup process. Occupancy indications from the LED is disabled during setup.
5. Move away from the sensor to avoid interference with light level detection. The sensor measures the light level for a 10 second period, then averages the readings and automatically sets the level that will be used as the new setting. The sensor will hold lights **OFF** when the ambient light exceeds this setting.
6. When the LED stops flashing, replace the Front Cover.

### \*Disabling Light Level

Press and hold the Light Level button over 5s (the green LED will be **ON** and then **OFF**). After pushbutton is released, the LED will flash quickly for about 10s. The light level will be set to its default value (maximum)

## TROUBLESHOOTING

### For any unexpected operation

1. Check DIP Switch settings.
2. Make sure the switches are set according to the defined settings in the DIP Switch Setting chart.

### Lights do not turn on with occupancy, and the LED does not flash:

1. Check that the circuit breaker has been turned back on.
2. The Ultrasonic Sensitivity setting may need to be increased.  
Turn clockwise as needed.
3. Check all sensor wire connections.
4. Check for line voltage input to the sensor.
  - If line voltage is present, replace the sensor.
  - If line voltage is not present, check line wiring.

### Lights do not turn off automatically:

1. The sensor may be experiencing activations from outside the controlled area or from some type of interference (see “Unwanted Sensor Activations” below).
2. Check all sensor wire connections.
3. Set sensitivity and time delay to minimum and allow the sensor to time out.  
If the lights turn **OFF**, the sensor is working properly (see number 1, above, and “Sensor Adjustment” for readjustment of sensor).

### Unwanted Sensor Activations (LED flashes):

1. The ultrasonic sensitivity may be too high causing detection outside of desired coverage area.  
Reduce the ultrasonic sensitivity (counterclockwise) as needed (see “Sensor Adjustment”).
2. Sensor located too close to HVAC or VAV vents with heavy air flow.  
Relocate the sensor.
3. Check if Light Level is enabled.
  - If occupancy indicator LED blinks every few seconds, sensor is using Light Level feature.
  - If Light Level functionality is not desired, press and hold for 5 seconds to return sensor to the default setting (maximum).

## ORDERING INFORMATION

Catalog#	Description
UT-355-1	360o Ultrasonic Occupancy Sensor, Line Voltage, up to 500 sq ft coverage
UT-355-2	360o Ultrasonic Occupancy Sensor, Line Voltage, up to 1000 sq ft coverage
UT-355-3	360o Ultrasonic Occupancy Sensor, Line Voltage, up to 2000 sq ft coverage
CA-1	Cosmetic adapter for ceiling installation with 4" square j-box or Wiremold #V5752 box

All sensors are White.

### WARRANTY INFORMATION

Wattstopper warrants its products to be free of defects in materials and workmanship for a period of five (5) years. There are no obligations or liabilities on the part of Wattstopper for consequential damages arising out of, or in connection with, the use or performance of this product or other indirect damages with respect to loss of property, revenue or profit, or cost of removal, installation or reinstallation.

### INFORMATIONS RELATIVES À LA GARANTIE

Wattstopper garantit que ses produits sont exempts de défauts de matériaux et de fabrication pour une période de cinq (5) ans. Wattstopper ne peut être tenu responsable de tout dommage consécutif causé par ou lié à l'utilisation ou à la performance de ce produit ou tout autre dommage indirect lié à la perte de propriété, de revenus, ou de profits, ou aux coûts d'enlèvement, d'installation ou de réinstallation.

### INFORMACIÓN DE LA GARANTÍA

Wattstopper garantiza que sus productos están libres de defectos en materiales y mano de obra por un período de cinco (5) años. No existen obligaciones ni responsabilidades por parte de Wattstopper por daños consecuentes que se deriven o estén relacionados con el uso o el rendimiento de este producto u otros daños indirectos con respecto a la pérdida de propiedad, renta o ganancias, o al costo de extracción, instalación o reinstalación.