

Catalog Number • Numéro de Catalogue • Número de Catálogo: LMPO-200

Country of Origin: Made in United States • Pays d'origine: Fabriqué en États-Unis • País de origen: Hecho en Estados Unidos



This unit is pre-set for Plug n' Go™ operation, adjustment is optional.

For full operational details, adjustment and more features of the product, see the DLM System Installation Guide provided with Wattstopper room controllers, and also available at www.legrand.us/wattstopper.

Installation shall be in accordance with all applicable regulations, local and NEC codes. Wire connections shall be rated suitable for the wire size (lead and building wiring) employed.

For Class 2 DLM devices and device wiring: To be connected to a Class 2 power source only. Do not reclassify and install as Class 1, or Power and Lighting Wiring.

SPECIFICATIONS:

Footcandle range LMPO-200.....	0 - 200 fc
Calibration	None, controlled by system software
Input voltage.....	24VDC
Sensor output.....	1-10VDC
Peak current.....	4.5 mA Maximum
Slew rate	1 minute full scale response time filter
Operating temperature	-40°F to 140°F (-40°C to 60°C)
Wire color code	
Red	Input Voltage +24 VDC
Black	Input Return/Output Common
Yellow	1-10VDC Output Signal
Housing	
Water tight, UV stabilized plastic with integral hood	
Mounting.....	½" NPT x .69" stem
Overall dimensions.....	2.55"L x 1.28"D

DESCRIPTION

The LMPO-200 is a daylight sensor specifically designed to be used in conjunction with an LMIN-104 Digital Interface Module or LMIO-301 DLM Photocell Input Module. The LMIN-104/LMIO-301 converts the 10 VDC signal from the photocell sensor to a digital signal that is shared across the DLM Local Network. The signal is forwarded as a BACnet object via a DLM network bridge to the segment network for load control via a DLM segment manager or BACnet-compatible Building Automation System (BAS).

INSTALLATION

Install the sensor on the roof of the building facing north. The sensor housing is equipped with a ½" NPT nipple and will thread into any suitable watertight box or fitting. Orient the housing so that the hood is above the lens to provide shielding.

WIRING

Connect the sensor to the LMIN-104 or LMIO-301 as shown.

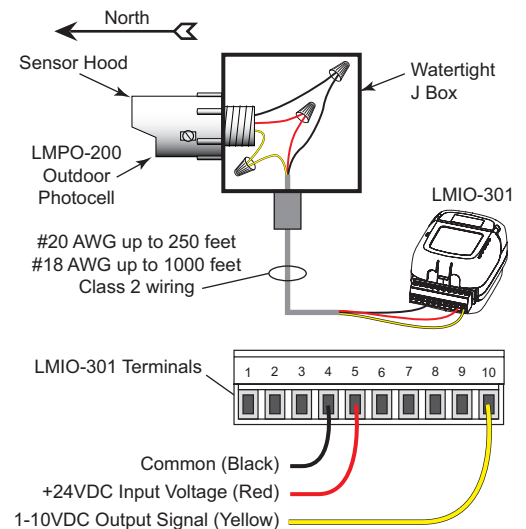
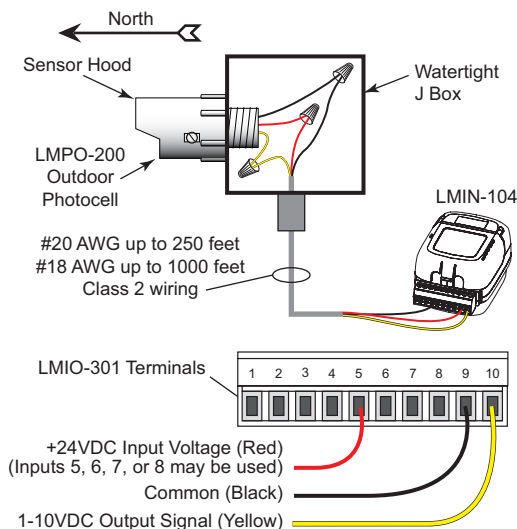

DLM SYSTEM CONNECTION

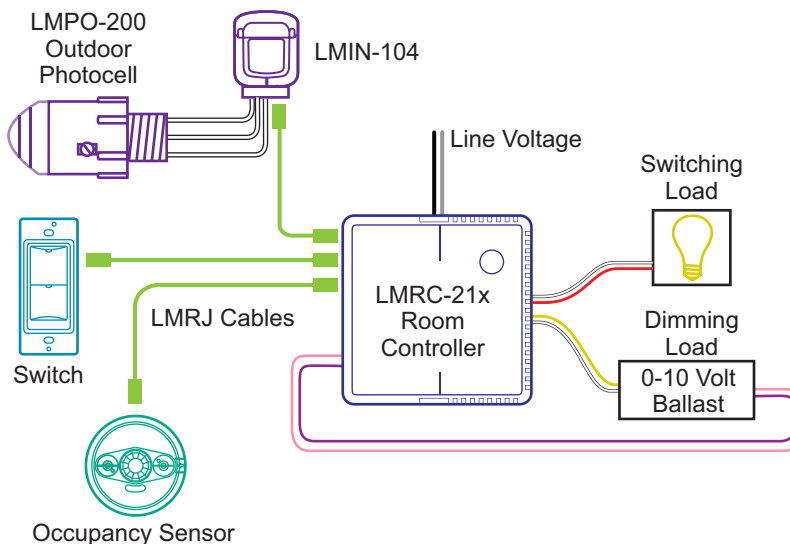

MAINTENANCE

At least once every two months wipe the lens clean with a non-scratching clean cloth. Check the housing for damage, and be certain that no moisture has penetrated the sensor, as this will likely render it inoperable.

WARRANTY INFORMATION

Wattstopper warrants its products to be free of defects in materials and workmanship for a period of five (5) years. There are no obligations or liabilities on the part of Wattstopper for consequential damages arising out of, or in connection with, the use or performance of this product or other indirect damages with respect to loss of property, revenue or profit, or cost of removal, installation or reinstallation.

INFORMATIONS RELATIVES À LA GARANTIE

Wattstopper garantit que ses produits sont exempts de défauts de matériaux et de fabrication pour une période de cinq (5) ans. Wattstopper ne peut être tenu responsable de tout dommage consécutif causé par ou lié à l'utilisation ou à la performance de ce produit ou tout autre dommage indirect lié à la perte de propriété, de revenus, ou de profits, ou aux coûts d'enlèvement, d'installation ou de réinstallation.

INFORMACIÓN DE LA GARANTÍA

Wattstopper garantiza que sus productos están libres de defectos en materiales y mano de obra por un período de cinco (5) años. No existen obligaciones ni responsabilidades por parte de Wattstopper por daños consecuentes que se deriven o estén relacionados con el uso o el rendimiento de este producto u otros daños indirectos con respecto a la pérdida de propiedad, renta o ganancias, o al costo de extracción, instalación o reinstalación.