



WP3SC250QT/PC



JOB NAME: _____
 DATE: _____
 TYPE: _____

DESCRIPTION

Large wallpack with aluminum precision die cast construction and tempered glass refractor. Lamp supplied.

SPECIFICATIONS

Finish:

Chip and fade resistant polyester powder coating.

Housing:

Die cast aluminum 1/2" NPS tapped holes top, both sides and back for conduit or photocontrol. Hinged refractor frame, Continuous silicone rubber gasket.

Reflector:

Specular anodized aluminum, removable for installation. Symmetrical light pattern maximizes distance between fixtures.

Photocell:

Swivel Photocell

UL Listing:

Suitable for wet locations. HID fixtures can be wired with 90° C supply wiring if supply wires are routed 3" away from the ballast.

Patents:

RAB sensor and fixture designs are protected under U.S. and International Intellectual Property laws.

Quad Tap:

Fixture works with 120, 208, 240, and 277 volts

Color:

Bronze

Weight:

22

DIMENSIONS

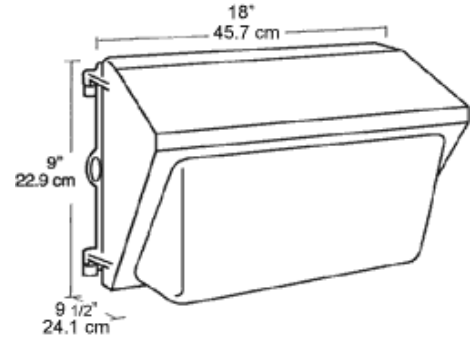

PHOTOMETRIC

250w HPS @ 16' Mounting Height

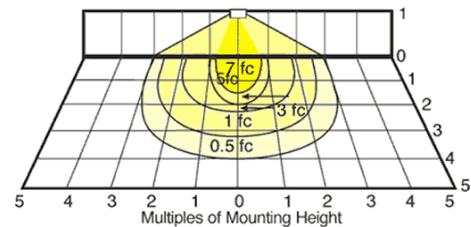

Mounting Height	Multiplier
8'	4
10'	2.6
12'	1.8
16'	1.0
20'	.6
24'	.5
32'	.3

Watts	Multiplier	HPS	vMH
200PS			.7
250	1.0		.7
250PS			.9
320PS			1.0
350PS			1.1
400	1.8		1.2
400PS			1.4

ORDERING INFORMATION

High Pressure Sodium
Lamp supplied with fixture

Total Watts	Lamp Type	Lamp Base	Ballast
250	ED28	Mogul	CWA-HPF QT

Starting Amps/ Operating Amps
120V 208V 240V 277V

Input Watts	LAMP ANSI	Initial Lumens	Lamp Hours
295	S50	28500	24000

Factory Installed Options
Add suffix to Catalog Number

Tamperproof screws (/TP)
Swivel Photocontrol (/PCS)
Single fusing for 120 and 277 volt (/F)

Quartz Restrike (/QR)
Double fusing for 208 and 240 volt (/FF)
Button Photocontrol wired for 208 - 277 volt (/PC2)
Button Photocontrol (/PC)

Note: Specifications may change without notice