



WP2SH100QT



JOB NAME: _____
 DATE: _____
 TYPE: _____

DESCRIPTION

Mid sized wallpack. All aluminum precision die cast construction with tempered glass refractor. Lamp supplied.

SPECIFICATIONS

Cutoff Lens:

Tempered glass.

Finish:

Chip and fade resistant polyester powder coating.

Housing:

Die cast aluminum, 1/2" NPS tapped holes top, both sides and back for conduit or photocontrol. Hinged refractor frame. Continuous silicone rubber gasket.

Reflector:

Specular anodized aluminum, removable for installation. Symmetrical light pattern maximizes distance between fixtures.

Color:

Bronze

Refractor:

Prismatic optics designed to minimize glare and throw light down and out. Heat resistant borosilicate glass.

UL Listing:

Suitable for wet locations. HID fixtures can be wired with 90° C supply wiring if supply wires are routed 3" away from ballast.

Patents:

RAB sensor and fixture designs are protected under U.S. and International Intellectual Property laws

Quad Tap:

Fixture works with 120, 208, 240 and 277 Volts

Weight:

19.55

DIMENSIONS

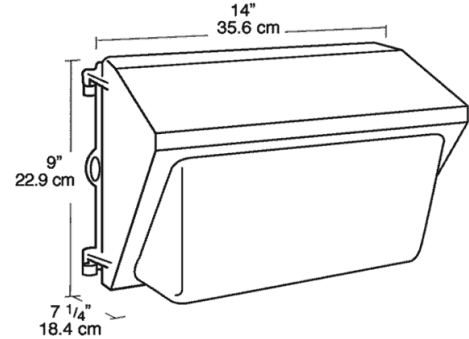

PHOTOMETRIC

150w HPS @10' Mounting Height

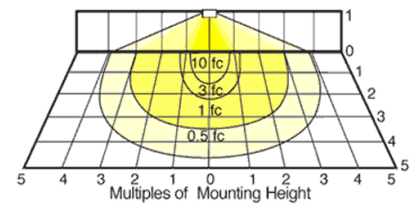

Mounting Height	Multiplier	Multiplier			
		Watts	HPS	MH	CFL
8'	1.6	175		.9	
10'	1.0	150PS		.9	
12'	.7	150	1.0	.8	
16'	.4	125PS		.7	
20'	.25	100	.6	.6	
		70	.4	.4	
		42			.2
		84			.4

ORDERING INFORMATION

High Pressure Sodium
Lamp supplied with fixture

Total Watts	Lamp Type	Lamp Base	Ballast
100	ED17	Medium	HX-HPF QT

Starting Amps/ Operating Amps
120V 208V 240V 277V

1.5/1.1	.8/.7	.7/.6	.6/.5
---------	-------	-------	-------

Input Watts LAMP Initial Lamp
Watts ANSI Lumens Hours

115	S54	9500	24000
-----	-----	------	-------

Factory Installed Options
Add suffix to Catalog Number

Tamperproof screws (/TP)
Swivel Photocontrol (/PCS)
Single fusing for 120 and 277 volt (/F)

Double fusing for 208 and 240 volt (/FF)
Button Photocontrol for 208 - 277 volt (/PC2)
Button Photocontrol (/PC)

Note: Specifications may change without notice