



WP2CSN50/PC



JOB NAME: _____
 DATE: _____
 TYPE: _____

DESCRIPTION

Wallpack with cutoff glare shield. All aluminum precision die cast construction with tempered glass lens. 30° cutoff strip included. Lamp supplied.

SPECIFICATIONS

Cutoff Lens:

Tempered glass.

Finish:

Chip and fade resistant polyester powder coating.

Housing:

Die cast aluminum, 1/2" NPS tapped holes top, both sides and back for conduit or photocontrol. Hinged refractor frame. Continuous silicone rubber gasket.

Reflector:

Specular anodized aluminum, removable for installation. Symmetrical light pattern maximizes distance between fixtures.

Refractor:

Prismatic optics designed to minimize glare and throw light down and out. Heat resistant borosilicate glass.

UL Listing:

Suitable for wet locations. HID fixtures can be wired with 90° C supply wiring if supply wires are routed 3" away from ballast.

Patents:

RAB sensor and fixture designs are protected under U.S. and International Intellectual Property laws

Color:

Bronze

Weight:

13.45

DIMENSIONS

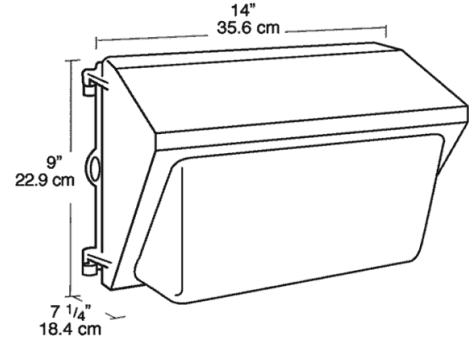

ORDERING INFORMATION

High Pressure Sodium
Lamp supplied with fixture

Total Watts	Lamp Type	Lamp Base	Ballast	Starting Amps/ Operating Amps				Input Watts	LAMP ANSI	Initial Lumens	Lamp Hours
				120V	208V	240V	277V				
50	ED17	Medium	R-NPF 120V	1.8/1.2				62	S68	4000	24000

Factory Installed Options
Add suffix to Catalog Number

Tamperproof screws (/TP)
Swivel Photocontrol (/PCS)
Single fusing for 120 and 277 volt (/F)

Double fusing for 208 and 240 volt (/FF)
Button Photocontrol for 208 - 277 volt (/PC2)
Button Photocontrol (/PC)

Note: Specifications may change without notice