



# WPTGSN100W



JOB NAME: \_\_\_\_\_  
 DATE: \_\_\_\_\_  
 TYPE: \_\_\_\_\_

## DESCRIPTION

Heavy duty die cast aluminum housing with prismatic glass refractor. With 1/2" bottom and back conduit knockout. Factory installed photocontrol optional. Lamp supplied.

## SPECIFICATIONS

### Back Plate:

Heavy die cast aluminum. 1/2" bottom conduit knockout. Knockouts for mounting to 3" or 4" junction boxes

### Ballast Housing:

Stamped steel painted white

### Reflector:

Die formed aluminum for wide light distribution

### UL Listing:

Suitable for wet locations

### Housing:

Heavy duty cast aluminum housing

### Patents:

The unique RAB Tallpack is protected by U.S. Patent D569,029; China Patent ZL200730149211.2; Taiwan Patent D124,864 and Canada Patent D121,993

### Refractor:

Heavy prismatic glass refractor

### Color:

White

### Weight:

8.95

## DIMENSIONS

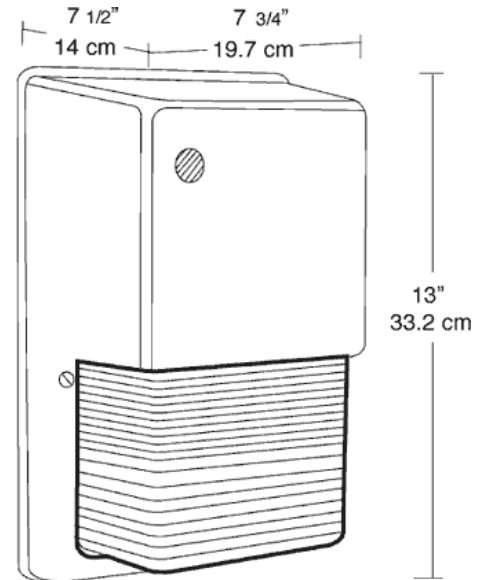

## PHOTOMETRIC

70w HPS @ 10' Mounting Height

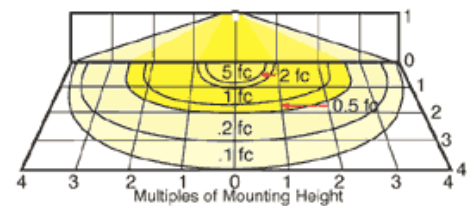

Mounting Height	Multiplier	HPS Watts	HPS Multiplier	CFL Watts	CFL Multiplier
8'	1.6	100	1.5	22	.2
10'	1.0	70	1.0	42	.5
12'	.7	50	.6		
16'	.4	35	.4		
20'	.25				
MH Watts Multiplier		100	1.4		

## ORDERING INFORMATION

**High Pressure Sodium**  
 Lamp supplied with fixture

Total Watts	Lamp Type	Lamp Base	Ballast
100	ED17	Medium	R-NPF 120V

Starting Amps/ Operating Amps			
120V	208V	240V	277V
3.1/2.1			

Input Watts	LAMP ANSI	Initial Lumens	Lamp Hours
115	S54	9500	24000

**Factory Installed Options**  
 Add suffix to Catalog Number

Tamperproof screws (/TP)  
 Swivel Photocontrol (/PCS)  
 Single fusing for 120 and 277 volt (/F)

Double fusing for 208 and 240 volt (/FF)  
 Button Photocontrol (/PC)

Note: Specifications may change without notice