



VX2SH70QTB-3/4

JOB NAME: _____
 DATE: _____
 TYPE: _____

DESCRIPTION

Cast aluminum housing for 50, 70 and 100 watt HPS, 50, 70 and 100 watt Metal Halide. Prismatic globe for low glare and even light distribution. Fixture mounts to junction box or can be wired inside the housing. Ceiling mounted with 1/2" (or 3/4") side and top conduit feed. Lamp supplied.

SPECIFICATIONS

Construction:

Die cast aluminum with brass screws

Globes:

Clear prismatic, heat resistant glass standard. White glass globes available. Colored and clear unbreakable RAB Permaglobes available for CFL only.

Guard:

One piece die cast aluminum with set screw

Optional Reflectors:

Highly reflective white baked polyester epoxy powder finish over a heavy gauge aluminum base. Reflectors thread onto fixtures.

Socket:

HID: Glazed porcelain 4kv pulse rated with nickel plated screw shell and spring contacts. CFL: White thermo plastic with integral clips for lamp retention.

UL Listing:

Suitable for wet locations. Complies with UL Standard 1598 for non-hazardous locations where the lamp, socket and wiring require protection from air, corrosive fumes, non-combustible dusts, moisture, non-explosive vapors and gases. For lamp base up installation only when outdoors.

Hub Size:

3/4" Tapped

Patents:

RAB sensor and fixture designs are protected under U.S. and International Intellectual Property laws.

Quad Tap:

Fixture works with 120, 208, 240 and 277 Volts

Color:

Black

Weight:

11.45

DIMENSIONS

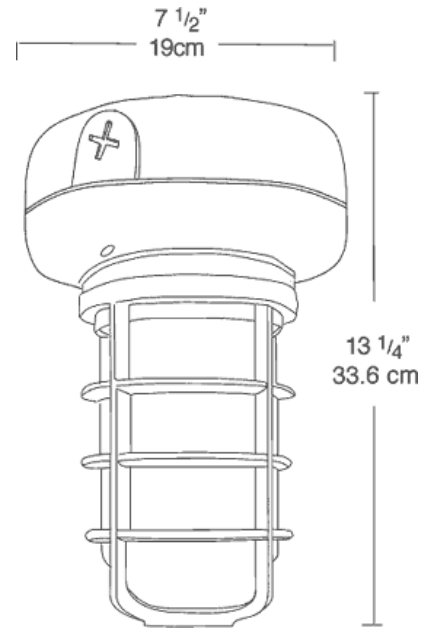

ORDERING INFORMATION

High Pressure Sodium Lamp supplied with fixture	Total Watts	Lamp Type	Lamp Base	Ballast	Starting Amps/ Operating Amps				Input Watts	LAMP ANSI	Initial Lumens	Lamp Hours
					120V	208V	240V	277V				
	70	ED17	Medium	HX-HPF QT	.8/.8	.5/.5	.4/.4	.4/.4	91	S62	6300	24000

Factory Installed Options
 Add suffix to Catalog Number

Note: Specifications may change without notice