

RWLED ROADWAY 50W 78W 105W 125W 150W INSTRUCTIONS LIGHTING

RAB[®]

Thank you for buying RAB lighting fixtures. Our goal is to design the best quality products to get the job done right. We'd like to hear your comments. Call the Marketing Department at 888-RAB-1000 or email: marketing@rabweb.com

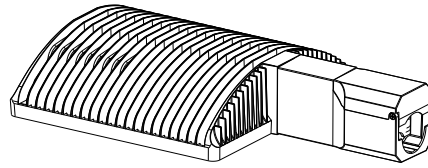

ROADWAY

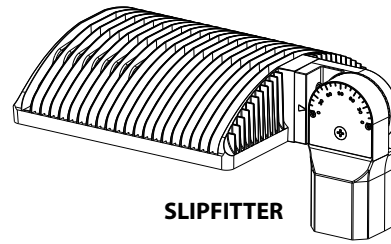

SLIPFITTER

IMPORTANT

READ CAREFULLY BEFORE INSTALLING FIXTURE. RETAIN THESE INSTRUCTIONS FOR FUTURE REFERENCE.

RAB fixtures must be wired in accordance with the National Electrical Code and all applicable local codes. Proper grounding is required for safety. THIS PRODUCT MUST BE INSTALLED IN ACCORDANCE WITH THE APPLICABLE INSTALLATION CODE BY A PERSON FAMILIAR WITH THE CONSTRUCTION AND OPERATION OF THE PRODUCT AND THE HAZARDS INVOLVED.

WARNING: Make certain power is OFF before installing or maintaining fixture. No user serviceable parts inside.

ROADWAY ARM MOUNTING

1. The **Roadway Arm** fits a 1", 1.25", 1.5" and 2" pole tenon.
2. Slide the **Fixture** on the pole tenon. Unlatch the **Arm Door** and place the appropriate **Pole Mounting Clamp** in the **Arm**. The tenon diameter is marked on the pole mounting clamp.
3. Secure the fixture on the pole by tightening the pole mounting clamp with the hardware provided.
4. Open the **Arm Cover Plate** to the **Splice Box**. Feed wires from **Pole** and fixture into the splice box. Make the necessary connections in the splice box and knot wires for strain relief.
5. Install the arm cover plate. Be sure the gasket and o-ring are in place. Tighten **Screws**, install the **Cap** and close the arm door.

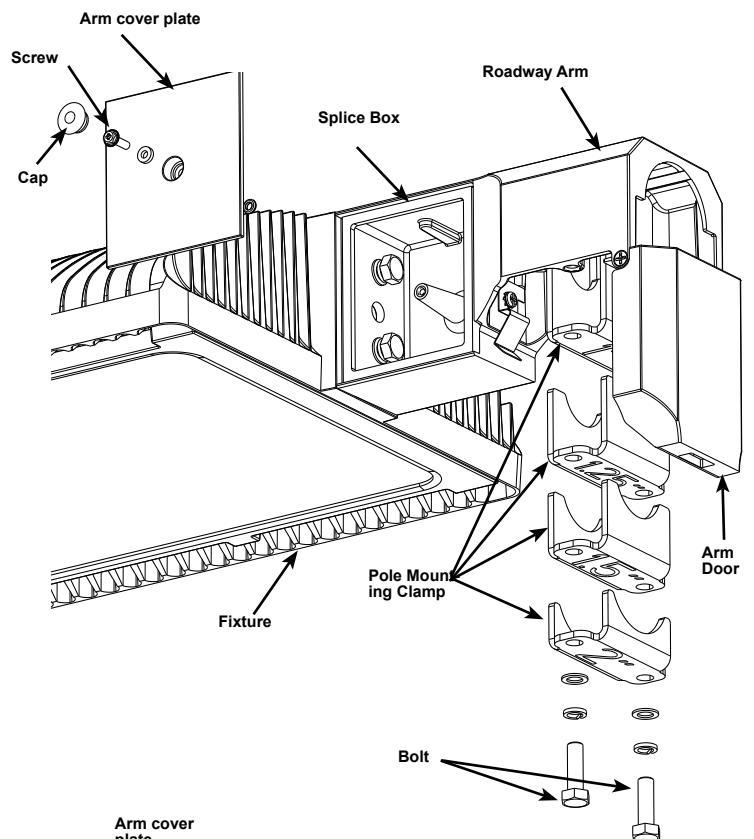

WEDGE MOUNTING

1. To tilt the fixture use the **Wedge** with hardware provided.
2. Open the **Arm Cover Plate** to the **Splice Box**. Unscrew the **Bolts** attaching the arm to the fixture.
3. Insert the wedge between the fixture and **Arm**. Be sure to place **Gasket** between fixture and wedge and also between wedge and arm. Replace the bolts to 3/8 -16 Bolts provided with the wedge. Tighten with the bolts.
4. Placing the wedge as shown the Fig, tilts the fixture by 5 degrees Upwards. To tilt the the fixture in opposite direction, rotate the Wedge by 180 degrees.

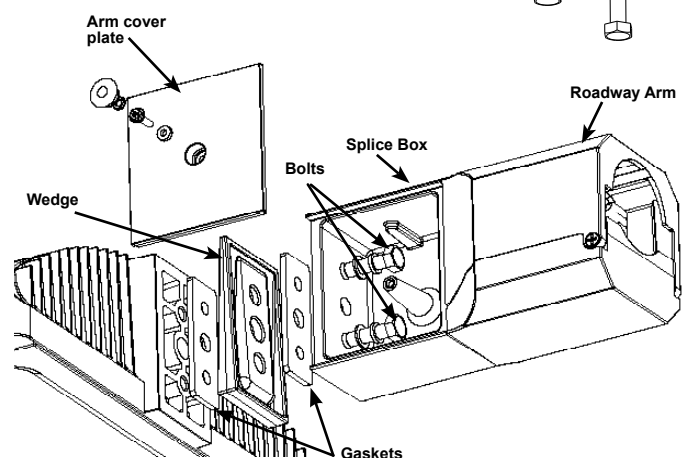

RWLED ROADWAY 50W 78W 105W 125W 150W INSTRUCTIONS LIGHTING



Thank you for buying RAB lighting fixtures. Our goal is to design the best quality products to get the job done right. We'd like to hear your comments. Call the Marketing Department at 888-RAB-1000 or email: marketing@rabweb.com

SLIPFITTER MOUNTING

1. The **Slipfitter** fits a 2 3/8" O.D. **Pole Tenon**. Place the slipfitter over the tenon and secure the fixture with 2 **Set Screws** on the side of the slipfitter.
2. Feed wires from **Fixture** through slipfitter and supply wires from **Pole**. Make the necessary connections in the slipfitter and knot wires for strain relief.
3. To adjust the angle of the slipfitter, remove 2 **screws** and remove the **Slipfitter Cover Plate**. Loosen the **Locking Bolt** and swivel fixture to desired angle. The graduation on the slipfitter cover plate can be used as guidelines to adjust the angle.
4. Tighten the **Locking Bolt**. Replace slipfitter cover plate. Tighten **Screws**.
5. Seal **Plug** using Teflon tape or silicone sealant.

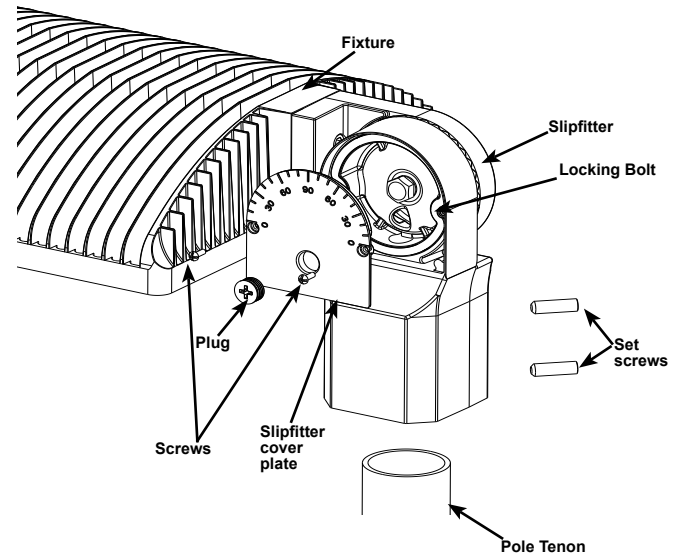

FIXTURE WIRING

Universal voltage driver permits operation at 120 to 277VAC, 50 or 60Hz. Units ordered with (/480V) suffix are 480V, 50Hz or 60Hz. Factory ordered fixtures with suffix (/PCS) are 120V swivel photocell and (/PCS2) are 277V swivel photocell. 6kV surge protector for 120 to 277VAC, 50 or 60Hz provided with the fixture. Wire the surge protector in the pole handle away from the fixture and at least 6" above ground.

1. Connect the black fixture lead to the (+) LINE supply lead and black surge protector wire.
2. Connect the white fixture lead to the (-) COMMON supply lead and white surge protector wire.
3. Connect the bare copper Ground wire from fixture to supply ground and green surge protector wire.

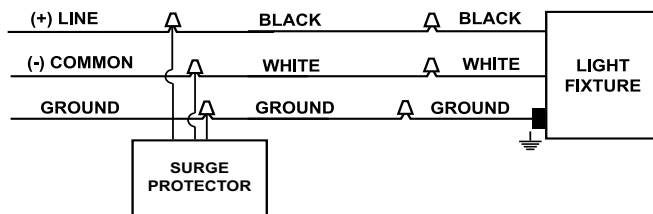

ACCESSORIES

Wedge can be ordered with

WEDGERW-A	Bronze Wedge
WEDGERW-W	White Wedge
WEDGERW-RG	Roadway Gray Wedge

Fixtures with Roadway arm can be provided with 120V -277V twist lock photocell (/PCT)

CLEANING & MAINTENANCE

CAUTION: Be sure fixture temperature is cool enough to touch. Do not clean or maintain while fixture is energized.

1. Clean glass lens with non-abrasive glass cleaning solution.
2. Do not open fixture to clean the LED. Do not touch the LED.

TROUBLESHOOTING

1. Check that the line voltage at fixture is correct. Refer to wiring directions.
2. Is the fixture grounded properly?
3. Is the photocell functioning properly (if used)?

RWLED ROADWAY 50W 78W 105W 125W 150W INSTRUCTIONS **RAB** LIGHTING

Thank you for buying RAB lighting fixtures. Our goal is to design the best quality products to get the job done right. We'd like to hear your comments. Call the Marketing Department at 888-RAB-1000 or email: marketing@rabweb.com

0-10V DIMMABLE WIRING

Universal voltage driver permits operation at 120V thru 277V, 50 or 60 Hz. For 0-10V Dimming, follow the wiring directions as in fig. 2.

1. Connect the black fixture lead to the (+) LINE supply lead.
2. Connect the white fixture lead to the (-) COMMON supply lead.
3. Connect the GROUND wire from fixture to supply ground. Do NOT connect the GROUND of the dimming fixture to the output.
4. Connect the purple fixture lead to the (V+) DIM lead.
5. Connect the gray fixture lead to the (V-) DIM lead.
6. Cap the yellow fixture lead, if present. Do NOT connect.

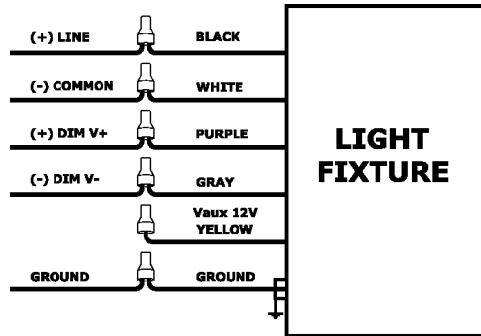
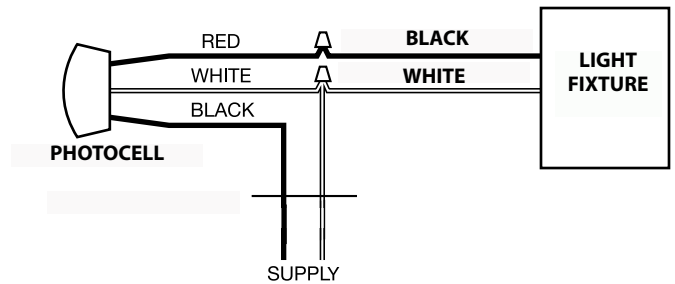

Fig. 2

PHOTOCELL INSTALLATION

Photocell may be installed in the field. Apply weatherproof silicone sealant to all plugs and unused conduit entries.

1. Remove close up plug on top of the wall mounting box.
2. Install photocell and wire as per diagram.
3. Use photocell rated for your supply voltage.



Patent: US: pat. D668,370; CN: ZL201230100154.X; MX: 38423; TW: pat. D156973; CA: © RAB Lighting Inc.
 Note: These instructions do not cover all details or variations in equipment nor do they provide for every possible situation during installation, operation or maintenance.