

SmartBox

Outdoor Motion Sensor
Installation Manual



It's easy
to add
motion detection
to all your
outdoor
lights!

RAB

Contents

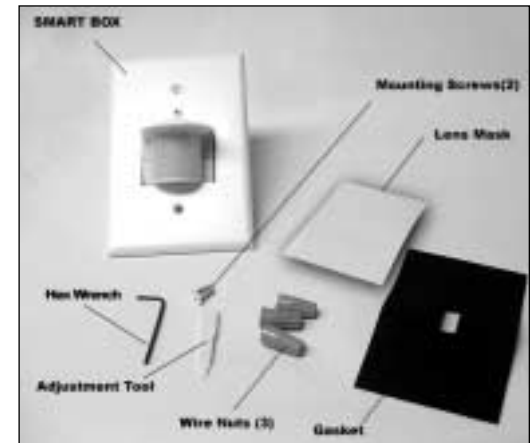

Specifications

Switching Capacity:

Relay On/Off Model:

500 watts Incandescent or
250 watts Fluorescent @120 volts

Hi/Lo Model:

Runs at 20% lamp wattage from
dusk to dawn. Brightens to full
wattage upon sensor detection.
180 watts Incandescent maximum.

Voltage:

120 Volts AC

Power Consumption:

One watt



UL Listing:

Raintight Photoelectric
Switch. Suitable for wet locations.

Time Adjustment:

5 seconds to 15 minutes

Quick Test Time:

5 second test time for fast installation.
Works day or night.

"No Hands" Auto Testing:

Auto mode starts after 3 minutes of
testing. No adjustment needed.

Built for Severe Conditions:

Double weatherproofing for long life.

Photoelectric Control:

Deactivates lights during daylight.
Fully adjustable for 24 hour
operation or custom applications.

Vandal Resistant Lens:

Hard lens resists casual vandalism.

Case Construction:

Precision molded Lexan®

Color Matched Lens:

Dark lens with black units.
White lens with white units.

Manual Override:

Double flip wall switch logic prevents
activation by short power outages.
Resets to auto at dawn. No extra
wiring needed.

LED Detection Indicator:

Glowes red day and night for
"on-guard" deterrence.

RF Immunity:

Circuits fully shielded for maximum
radio frequency immunity.

Why RAB Sensors are Best for You

Smaller is better! SmartBox uses state-of-the-art surface mount technology (SMT), just like cellular phones and beepers. SMT gives you more reliability, greater RF immunity, and a compact sensor that can fit neatly where others cannot.

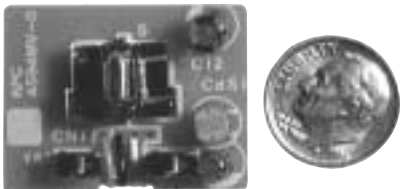

Wider is better! The wide 180° view detects movement along the entire side of a building with only one compact sensor. It will detect people as they exit or enter. It takes several conventional sensors to get the same coverage.

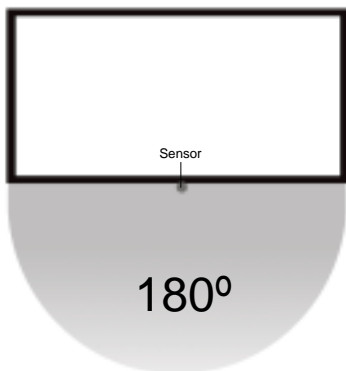

Molded is better! No leaky gaskets or bug hotels with SmartBox. The hard lens is molded as part of the case. It's vandalproof, rainproof, bugproof and absolutely sealed.



Cautions

- All wiring **MUST** comply with local electrical codes and should be installed by a qualified electrician.

- Read entire Installation Manual before proceeding.

TURN OFF POWER BY REMOVING POWER FUSE OR TURNING OFF CIRCUIT BREAKER BEFORE INSTALLATION.

- Total lighting load must not exceed:
Relay On/Off Model: 4 amps, 500 watts incandescent quartz or 250 watt fluorescent at 120 volts. To switch more wattage, an electrician can install an additional relay.
Hi/Lo Model: 180 watts quartz and incandescent only.

- Line Carrier Remote Control Systems such as X-10, Leviton or Radio Shack are incompatible with sensors and cause false activations.

- Do not install on circuits feeding motor loads such as kitchen appliances, HVAC equipment, washer/dryer or garage door openers.

- Sensor functions best when movement is across its detection pattern, not towards the sensor.

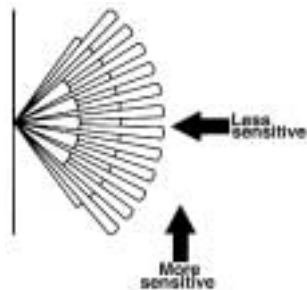

- Mount 3'-6' high for optimum range and direction.

Assembly and Wiring

Note: The SmartBox time control is factory set for 5-8 minutes and for night only operation. For other settings, see "Aiming and Walk Testing" section (Pg.9). It is easier to set the time control on the sensor prior to installation.

1. SmartBox requires a vertically mounted single gang, full size outlet box.
2. Position gasket on back of switch plate.
3. Bring power leads and sensor leads into box.
4. Attach ground wire(s) to outlet box grounding screw.
5. Strip 1/2" of insulation from all leads. Connect as shown in Wiring Diagram on page 6.
6. Twist on wire nuts. Secure with electrical tape.
7. Align gasket to insure proper seal. Fasten SmartBox to outlet box. Use silicone sealant around all openings.
8. Adjust tilt angles of the sensor. Tilt down if necessary to limit range, tilt up to increase range. Tighten tilt set screw.

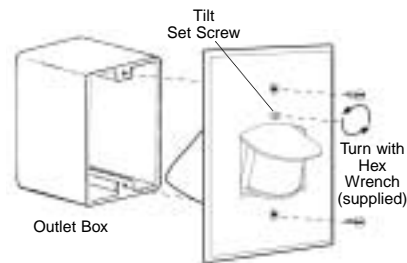

9. SmartBox may be painted to match the building, if desired. Mask the lens area carefully with the lens Painting mask provided or with masking tape. Sand surfaces to be painted with fine sandpaper.

10. Turn on power.
12. Conduct Walk Test to adjust sensor response.

Wiring Diagrams

Basic Wiring Diagram

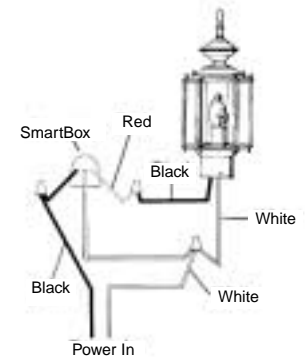

To switch more than rated load (Relay model only)

Hi/Lo sensors can not accept an auxiliary relay to increase their switching capacity.

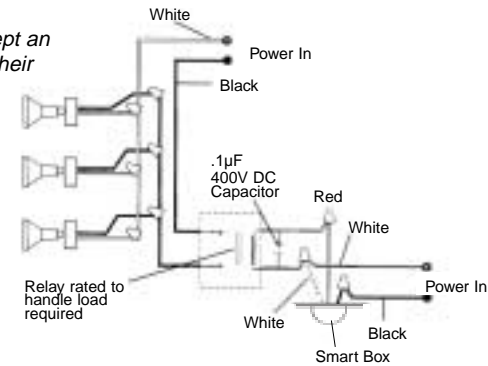

Multiple Sensors:

Wiring more than one sensor together is recommended only for the experienced installer because it becomes difficult to troubleshoot. Single sensors that control their own lights pinpoint movement more accurately and operate better.

Power Quality:

Sensors should not be installed on a circuit that also feeds motor loads such as HVAC equipment, kitchen appliances, or garage door openers. If voltage varies significantly from 120 volts, sensors may malfunction.

How Does SmartBox Work?

The SmartBox infrared sensor “sees” small temperature changes caused by the motion of people or cars within its Detection Zone and turns on lights automatically. It welcomes visitors and may deter intruders.

How long do the lights stay on?

Lights remain on as long as there is movement within the Detection Zone. In Hi/Lo Model, lights revert to dim. Once the zone is vacated, lights can be adjusted to remain on approximately 5 seconds up to 15 minutes.

The Hi/Lo Model will keep lights on at 20% wattage from dusk until dawn and then brightens to full wattage when movement is detected.

Will the sensor detect animals?

SmartBox may detect large animals. Having animals trigger the sensor can give property a “lived-in” look. You can limit animal detection by placing opaque weatherproof tape on the lower part of the lens or using the bottom mask on the Lens Mask Kit provided.



What does Manual Override do?

Keep lights on by flipping the wall switch two times within 5 seconds. Sensor resets to auto mode at dawn. No extra wiring needed.

How are the Time, Sensitivity and Photocell adjusted?

- **Time Control:** Sets the time that lights will remain on after the Detection Zone is vacated from approximately 5 seconds to 15 minutes. Use the adjustment tool provided to turn clockwise to increase the time.
- **Factory Setting:** 5-8 minutes.

- **Photocell Control:** For night only operation, use the tool provided or a small screwdriver to turn the Photocell Control all the way counter-clockwise (to the moon symbol). For operation in low level lights, turn the knob all the way clockwise (to the sun symbol). Adjust counter-clockwise to have the sensor come on later at dusk, clockwise to have it come on earlier.
- Hi/Lo Model: Turning photocell control will show when the sensor “thinks” the current ambient light level = night, because the lights will turn on low at 20% wattage.*
- Factory setting: Night Only

- **Sensitivity:** Increases or decreases the responsiveness and range of the sensor.

Control Panel:

Turn controls gently using the adjustment tool provided. Do not force past stops.

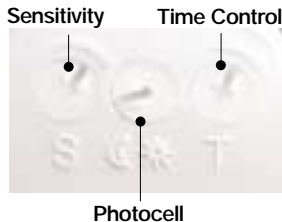

Picking A Location

Location Considerations:

- Choose a location from which the sensor can “see” all the paths of movement that will be illuminated by its lights.
- Smart Box may be painted to blend in with walls. Carefully apply masking tape to the sensor lens or use the Lens Mask Kit provided before painting!
- Sensor functions best when the direction of suspected movement is across its detection pattern, not towards the sensor.
- If wall mounting, locate 5-8' high for optimum range. Lower mounting height will reduce range.
- The sensor has a “Double Look Down” Lens with one “Look Out” zone and two “Look Down” zones, for excellent detection both at long and close range.

Detection Pattern

- Detection extends out a maximum of 40 feet and is 180° wide.
- To reduce the Detection Pattern length, adjust the tilt set screw underneath the sensor using the hex wrench provided.

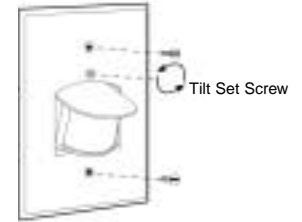

- To reduce Detection Pattern width, mask the sides of the lens with the Lens Mask Kit provided or opaque weatherproof tape.
- If sensor is mounted by a doorway at the top of stairs, be aware that the elevated mounting height may extend the sensors range.

Detection Pattern:

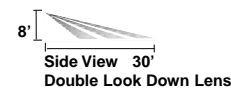
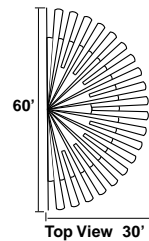

Aiming and Walk Testing

Test Period:

The sensor has a 3 minute Test Period which allows it to be aimed and walk tested day or night.

- For the first 30 seconds, the lights will be turned on. During this time, test that all fixtures and lamps function properly.
- For the next 3 minutes, the sensor will keep lights on for 5 seconds each time it detects movement in its Detection Zone. The sensor will change to Automatic Mode after the 3 minute Test Period.
- If another 3 minute Test Period is desired, turn the power off for at least 10 seconds and back on again.

Walk Test:

The purpose of the Walk Test is to check and adjust the coverage pattern.

1. Aim the sensor approximately to cover the area you desire.
2. Start outside the Detection Zone and walk across the zone until the lights go on. As distance from the sensor increases, it will take more movement to be detected. For instance, at 10 feet, a half step will be enough. while at 30 feet, several steps will be necessary.

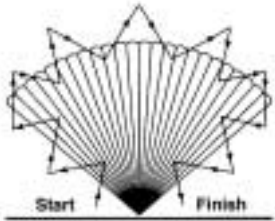

3. To shorten the range, use the lens masks provided or tilt the sensor down.
3. Repeat steps #2 and #3 until you are satisfied with the coverage.
4. The Time Control is factory set between 5-8 minutes. This period starts after the movement in the Detection Zone ceases. If less time is desired, turn the time control counterclockwise. For more time, turn the control clockwise.
5. The sensor is factory set for night only operation. To obtain operation in low level light, turn the Photocell Control clockwise to the sun symbol. Intermediate settings will allow the sensor to operate earlier or later at dusk.

6. Your sensor is ready for operation. See the Technical Tips pages if additional help is needed.

Control Panel:

Turn controls gently using adjustment tool provided. Do not force past stops.

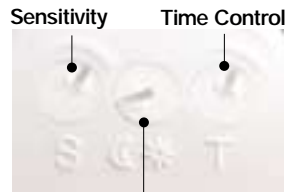

Photocell
Turn to moon symbol for night only

Turn to sun symbol for 24 hour operation (lights turn on night and day)

Technical Tips: Lights Do Not Turn Off

1. Make sure sensor is not aimed at something that would move or change temperature such as waving branches, water, air conditioners, windows or heating vents - even on neighboring property. You can test for infrared sources in the area by placing a box or bag over the sensor. Put sensor into Test Mode. After the initial 30 seconds of the lights being on, lights should stay off. Wave your hand inside the bag in front of sensor. Lights should go on and then time out. If sensor operates properly when covered, check items 2-6.

Problem: Sensor is triggered by unwanted movement or heat source.

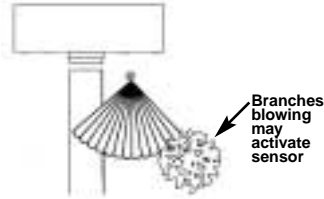

Solution: Mask lens in the direction of the source. Move sensor or source.

2. Make sure sensor is mounted firmly and does not move even slightly when touched. If it moves, tighten all screws.
3. Make sure that SmartPost is not mounted on an unstable pole that will move in the wind.
4. Was sensor wired hot? If so, circuitry may have been damaged.
5. Make sure sensor is not aimed within 30 feet of a road.

Problem: Passing cars activate sensor.

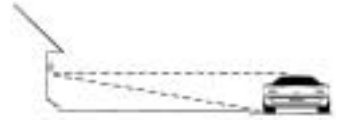

Solution: A 30' safety zone between the sensor and road is recommended to avoid activation from passing cars.

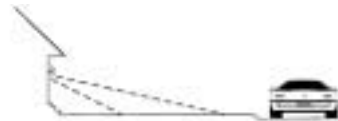

You may also mask top of sensor lens to reduce range or simply rotate sensor so it is not aimed in the direction of the street.



6. Make sure heat from lights is not triggering sensor. Make sure the sensor is below and as far as possible away from lights.

7. Hi/Lo Models only: Remember that the lights will stay on in low mode at 20% wattage from dusk to dawn. This is normal operation. If the Photocell Control is turned to the sun symbol, the lights will stay on in low mode in low level light and night. If you desire low mode from dusk until dawn only, turn the Photocell Control fully counter clockwise to the moon symbol.
Tips 1-6 above apply only if the lights are staying on in high full wattage mode.

Technical Tips: Range appears limited

1. Check that the sensor is level from side to side and pointed at the area you desire. If unit is tilted, part of the Detection Zone may be high in the air over peoples heads.



Solution: Position sensor exactly level from side to side.



2. Check that the sensor is not mounted too high. If mounted above 20 feet, much of the usable range will be lost.

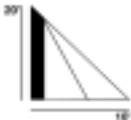

Solution: Mounting at 4' to 8' allows maximum range.



3. If sensor is painted, make sure there is no paint on the lens and that the lens paint mask is removed.

4. Check that movement is not directly towards sensor. Sensor will see movement across its pattern more quickly. To fix, move the sensor.

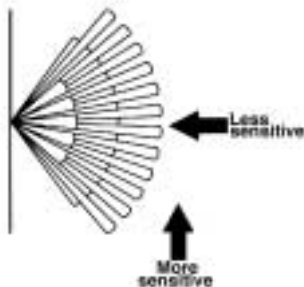

5. Check that movement far away and directly towards sensor is not entirely within one Detection Pattern finger.

Problem: Sensor will not detect until movement crosses from one finger into a second finger.

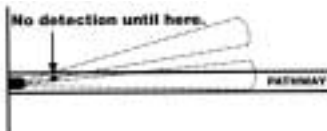

Solution: "Micro Adjust" sensor by tilting mounting plate 1/16". This small adjustment may move the zones to allow earlier detection.



Technical Tips: Lights Do Not Turn On

1. Check that lightbulbs and fixtures work. Compare wiring to the Wiring Diagram in this manual. Check that the power is on.

2. If installing during daylight, remember that the sensor will provide a 3 minute Test Period after power is turned on. After 3 minutes, the sensor will switch to Automatic Mode and will not work during daylight if the Photocell Control is turned to or near the night only position (fully counter clockwise to the moon symbol).

If you require another 3 minute Test Period, turn the power off for at least 10 seconds and back on again.

3. Check that lights from other sources, such as adjacent porch lights, garden lights, streetlights or lights from inside the house are not in the sensor's view. See #1 under "Lights Turn Off Too Quickly".

4. Was sensor wired hot? If so, circuitry may have been damaged.

5. If sensor is painted, make sure there is no paint on the lens and that the lens paint mask is removed.

Lights Turn Off Too Quickly

1. Check if sensor is being "tricked" by reflected light. If lights shine or reflect into the photocell, (located behind the lens), the unit will go on briefly and turn off thinking it is daytime.

Problems:
Lights reflect into photocell or lights shine directly into photocell.

Solution: Adjust Photocell Control slightly clockwise, toward the sun symbol. This allows the sensor to function in brighter ambient light conditions. Alternatively, move the lights or mask the lens in the direction of the lights or reflections. If the problem persists, it may be necessary to increase the length of the sun shield over the sensor using weatherproof tape or some other material.

Technical Tips: Lights Turn On and Off Incorrectly

1. Make sure the sensor is installed on its own dedicated circuit free of motor loads such as HVAC equipment, kitchen appliances or garage door openers.

2. It is not recommended to wire sensors in parallel. More than one sensor wired together makes them difficult to troubleshoot. Disconnect multiple sensors and test separately.

3. Keep all people completely out of the detection pattern to make sure the sensor is not detecting them.

4. Make sure sensor is located below and as far as possible from its lights. Heat from the lights may trigger the sensor.

Solution: Move sensor below and away from the lights.

5. Make sure lights are not visible from or reflecting back into sensor. Check for white or reflective surfaces close to the sensor.



Solution: Aim sensor away from lights and reflective objects or mask the lens in the direction of the light or reflection.



6. Heavy rain, snow or high winds may activate the sensor occasionally.

Solution: Reduce sensitivity control settings, mount in a more protected area and/or mask the lens if this is a constant problem.

7. Make sure sensor is not aimed within 30' of a road or sidewalk. Passing cars will activate sensor.

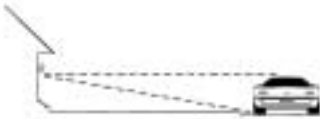

Solution: Mask the top of the lens to reduce Detection Pattern Length.



8. Self ballasted PL lamps may cause cycling (on-off).

9. Check solutions 1,2,3,5 & 6 under "Lights Do Not Turn Off" (Page 10).

Technical Tips: Lights Turn On For Unknown Reasons

1. Lights may turn on occasionally during rain, snow and windstorms because the sensor is detecting changes in temperature. If this is a constant problem, mount the sensor in a more protected area.

2. Tilt the sensor lower - it may be seeing distant objects moving.

3. You may not be aware that animals have triggered sensor. Check sensor aiming to reduce nuisance triggering or mask the lower part of the lens with opaque weatherproof tape.

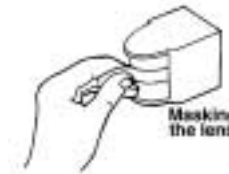

4. The sensor may turn on occasionally during voltage surges.

5. A possible source of "mysterious" sensor activations are strong local radio signals. Check for nearby CB, Ham, VHF radio transmitters or Cellular telephones. The sensor may be activated, but will not be permanently impaired by these signals.

5. Check all the solutions mentioned under "Lights Turn On and Off Incorrectly" on Pg. 13.

Limited Warranty

Your SmartBox will be promptly replaced or repaired, at our option, if it proves to be defective in workmanship or materials within 5 years of purchase.

For repair or replacement, please call the Tech Help Line at 888 RAB-1000 for instructions.

If the sensor is out of warranty or damage is unrelated to its original manufacture, return your unit freight prepaid to the address below. Please include a description of the problem and a check for \$20.00 (made out to RAB Electric). We will repair or replace your unit promptly.

Under no circumstances shall RAB Electric be liable for any incidental or consequential damages arising out of or in connection with the use or performance of this product or other indirect damages with respect to loss of property or revenue or cost of installation, removal or re-installation. This warranty gives you specific legal rights and you may also have other rights which vary from state to state. SmartBox is designed to detect people or cars in the detection area. It should not be construed as a theft or crime prevention device. RAB does not accept responsibility for any damages resulting from intrusion or other crimes.

Toll Free Technical Assistance

If you need technical assistance, please do the following:

1. Re-read the Technical Tips sections of this manual.
2. Call the Tech Help Line at 888 RAB-1000, 8AM to 4PM Eastern Time M-F and we will be glad to help you. Before you call, please have the following information handy:
 - a) Catalog number of your unit;
 - b) Wattage, types and locations of lights connected to the sensor;
 - c) The electrical circuit on which the sensor is installed. What else does it feed? How is the sensor power switched?
 - d) Serial Number (4 digits) on the back of the sensor.
 - e) This installation Manual

Note: RAB Electric cannot give electrical wiring instructions by phone. Please consult a qualified electrician.



RAB ELECTRIC MANUFACTURING, INC.
170 Ludlow Avenue, Northvale, NJ 07647 USA
Over 25 warehouses nationwide.

Tech Help Line	Fax Back	Website	e-mail
888 RAB-1000	888 RAB-1236	www.rabweb.com	sales@rabweb.com

©RAB Electric, 9/01