

PANEL 1X4

LED EMERGENCY BATTERY BACK UP INSTALLATION INSTRUCTIONS

RAB
LIGHTING

Thank you for buying RAB lighting fixtures. Our goal is to design the best quality products to get the job done right. We'd like to hear your comments. Call the Marketing Department at 888-RAB-1000 or email: marketing@rabweb.com

IMPORTANT

READ CAREFULLY BEFORE INSTALLING FIXTURE. RETAIN THESE INSTRUCTIONS FOR FUTURE REFERENCE.

Fixtures must be wired in accordance with the National Electrical Code and all applicable local codes. Proper grounding is required for safety. THIS PRODUCT MUST BE INSTALLED IN ACCORDANCE WITH THE APPLICABLE INSTALLATION CODE BY A PERSON FAMILIAR WITH THE CONSTRUCTION AND OPERATION OF THE PRODUCT AND THE HAZARDS INVOLVED.

WARNING: Make certain power is OFF before installing or maintaining fixture.

THIS IS AN EMERGENCY BATTERY BACKUP FIXTURE THAT CONTAINS A RECHARGEABLE NICKEL-CADMIUM BATTERY. THE BATTERY MUST BE RECYCLED OR DISPOSED OFF PROPERLY.

SAFETY INSTRUCTIONS

WARNING: Risk of fire or electric shock. Suitable for Damp locations where the ambient temperature is 0°C minimum, +50°C maximum. Not suitable for heated air outlets and wet or hazardous locations. Do not install near gas or electric heaters.

WARNING: Suitable for 9/16" or 15/16" Flat Tee Grid in both Insulated Ceilings and Non-Insulated Ceilings. Access above ceiling required.

WARNING: Do not handle energized fixture when hands are wet, when standing on wet or damp surfaces, or in water.

WARNING: Vapor barrier must be suitable for 90°C.

WARNING: Fixture to be independently supported to building structure.

RECESSED CEILING MOUNTING

The fixture is suitable only for INDOOR RECESSED CEILING application. Charging indicator test switch should be visible and accessible and be located nominal 2 feet from the fixture. Access above the ceiling is necessary.

To mount in an insulated or non-insulated ceiling - 9/16" or 15/16" exposed Flat Tee Grid Ceiling follow the steps below.

1. Rotate and slide the **Housing** as required to fit through the **Tee-Grid Bar** and place it as indicated by the directional arrow in figure.
2. Bend the pre-installed **Grid Clips** (4) to secure the **Housing** to the **Tee-Grid Bar**.
3. Support wires are required by Installation Codes. Support the **Housing** to the building structure by **Support Wires (supplied by others)** through the **Grid Clip Hole**.
4. Make sure that the orientation of the **Splice Box** and **Access Plate** faces an accessible tile to make electrical splices.
5. Loosen **Access Plate Screw** and remove the **Access Plate**. Knock out appropriate **Conduit Knockouts** on the **Access Plate** to route input conduit. Use appropriate conduit connectors as required by code.
6. Connect wires as shown in wiring diagram. Push all wires back into the **Splice Box**. Connect Inverter Plug only after supply wiring is complete. (see wiring instructions). Be careful not to pinch wires.
7. Install the **Switch Plate** (along with the charging indicator) in a suitable **Junction Box (by others)** in an adjacent ceiling tile. It should be located nominal 2 feet from the fixture.
8. Replace **Access Plate** and tighten **Access Plate Screw**.

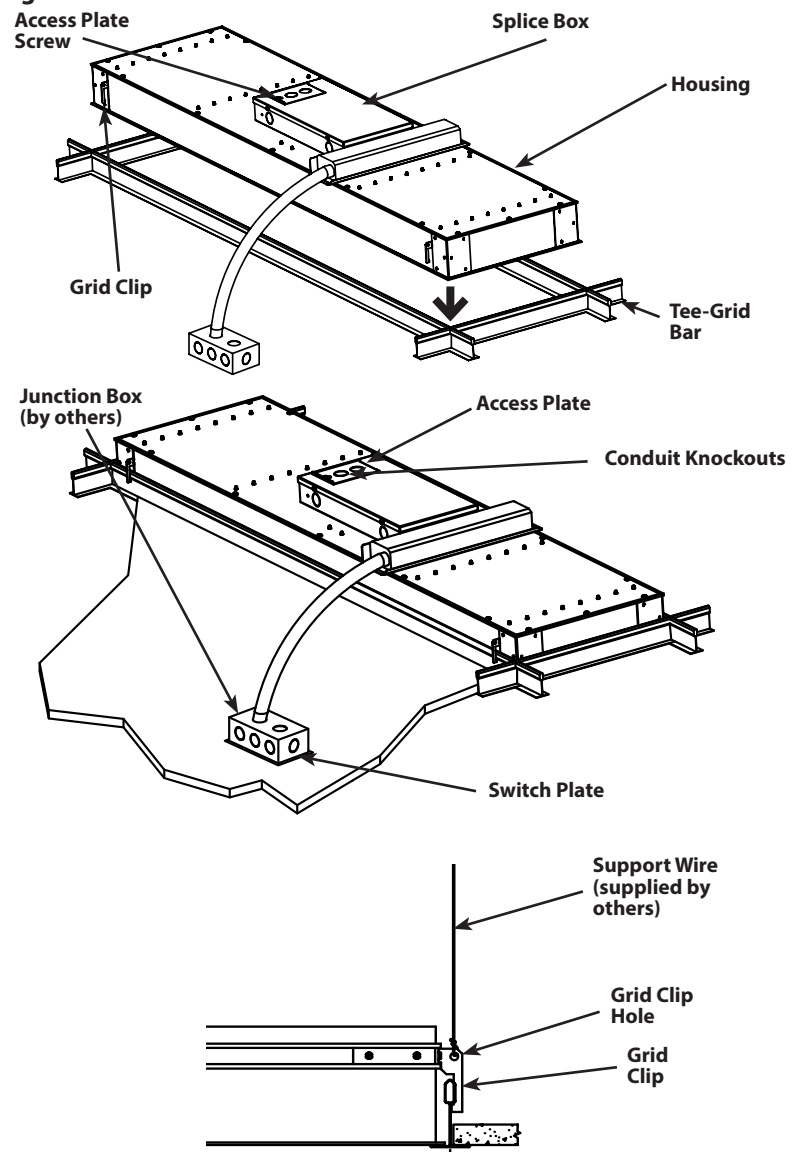

PANEL 1X4

LED EMERGENCY BATTERY BACK UP INSTALLATION INSTRUCTIONS



Thank you for buying RAB lighting fixtures. Our goal is to design the best quality products to get the job done right. We'd like to hear your comments. Call the Marketing Department at 888-RAB-1000 or email: marketing@rabweb.com

WIRING

CAUTION: THIS IS AN EMERGENCY BATTERY BACKUP FIXTURE. Voltage could be present in Battery. To prevent high voltage from being present on output leads, inverter connector must be open. Do not join inverter connector until installation is complete and AC power is supplied to the emergency ballast.

NOTE: Make sure that the necessary branch circuit wiring is available. An unswitched AC source of power is required. The emergency ballast must be fed from the same branch circuit as the AC ballast.

Do not use any supply voltage other than those specified below.

PANEL1X4/E2 120V-277V, 50/ 60Hz

1. Connect the UNSWITCHED black fixture lead to the HOT supply lead.
2. Connect red and black lead together, if not using a switching method.
3. If switching, connect SWITCHED red lead to a switch.
4. Connect the COMMON fixture lead to the COMMON supply lead.
5. For 0-10V Dimming, connect DIM (+) purple lead and DIM (-) gray lead to 0-10V dimmer. Do not connect the yellow lead.
5. Connect the GROUND wire from fixture to supply ground. Do NOT connect the GROUND of the dimming fixture to the output.
6. All unused leads must be capped and insulated.
7. After installation is complete, supply AC power to the emergency ballast and join the inverter connector.
9. At this point, power should be connected to both the AC ballast and the emergency ballast, and the Charging Indicator Light should illuminate indicating the battery is charging.
10. A short-term discharge test may be conducted after the emergency ballast has been charging for one hour. Charge for 24 hours before conducting a long-term discharge test. Refer to OPERATION.

TROUBLESHOOTING

1. Check that the line voltage at fixture is correct. Refer to wiring directions.
2. Is the fixture grounded properly?

OPERATION

1. When AC power is applied, the charging indicator light is illuminated, indicating that the battery is being charged.
2. When power fails, the emergency ballast automatically switches to emergency power (internal battery), operating at reduced illumination. The emergency ballast supplies 7W of power (measured at nominal battery voltage) at a maximum rated current of 270mA with a maximum voltage of 50VDC in emergency mode for a minimum of 90 minutes.
3. When AC power is restored, the emergency ballast automatically returns to charging mode.

CLEANING

CAUTION: Be sure fixture temperature is cool enough to touch. Do not clean or maintain while fixture is energized.

1. Clean acrylic lens & fixture with non-abrasive cleaning solution.
2. Do not open fixture to clean the LEDs. Do not touch the LEDs.

MAINTENANCE

Although no routine maintenance is required to keep the emergency ballast functional, it should be checked periodically to ensure that it is working. The following schedule is recommended:

1. Visually inspect the charging indicator light monthly. It should be illuminated.
2. Test the emergency operation of the fixture at 30-day intervals for a minimum of 30 seconds.
3. Conduct a 90-minute discharge test once a year. Fixture would operate at reduced illumination for a minimum of 90 minutes.

To reduce the risk of electric shock, disconnect both normal and emergency power supplies and converter connector of the emergency ballast before servicing. Do not attempt to service the emergency ballast. The use of accessory equipment may cause an unsafe condition. Do not use this product for other than intended use. Refer any servicing indicated by these checks to a Qualified Service Personnel.

Note: These instructions do not cover all details or variations in equipment nor do they provide for every possible situation during installation, operation or maintenance.

WIRING DIAGRAM for EMERGENCY OPERATION at 120V-277V

Emergency Ballast and AC Ballast must be fed from the same circuit

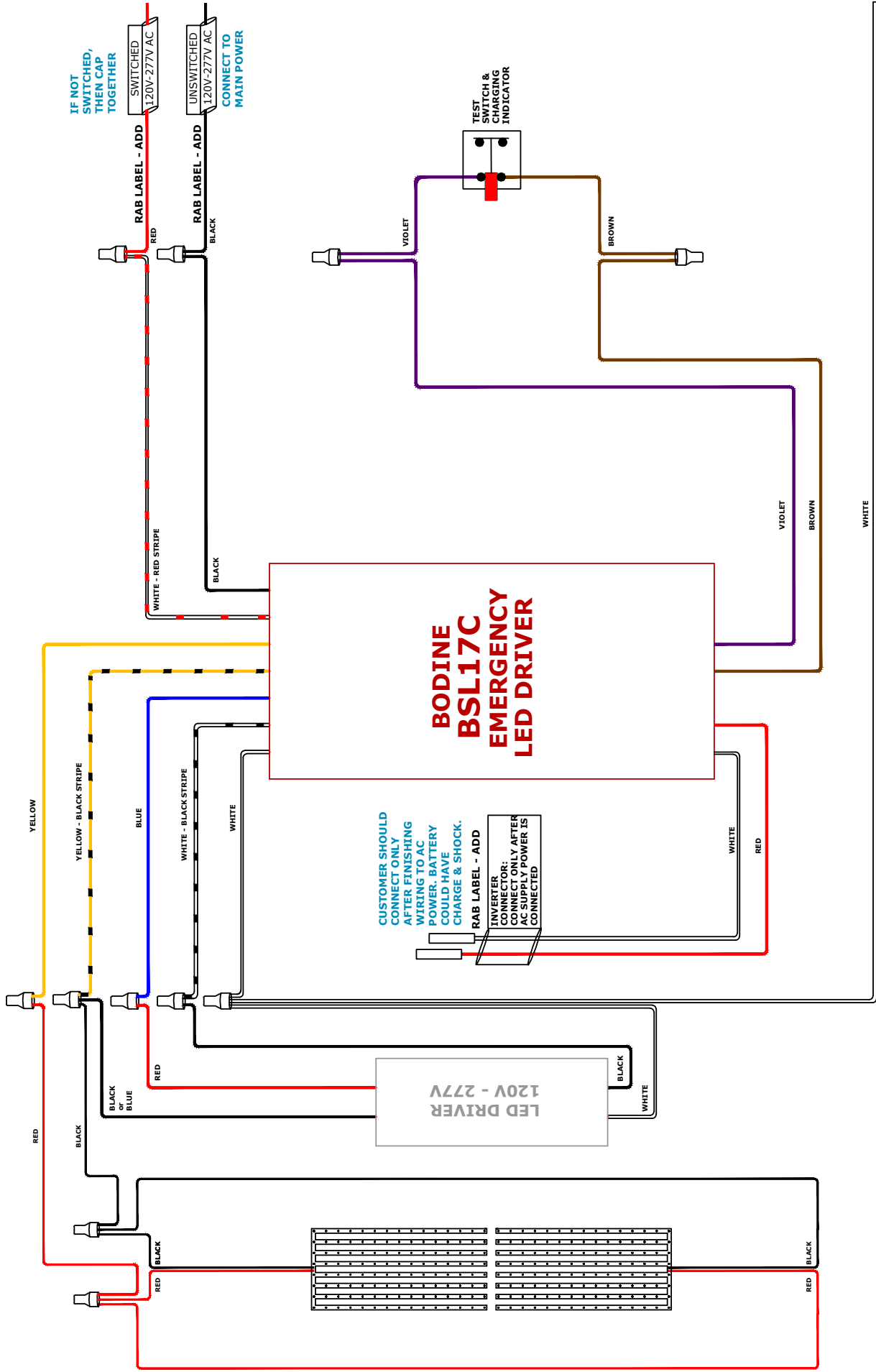

WIRING DIAGRAM for EMERGENCY OPERATION at 120V-277V with 0-10V DIMMING

Emergency Ballast and AC Ballast must be fed from the same circuit

