

# RAB LIGHTING

## FX150QT



JOB NAME: \_\_\_\_\_  
 DATE: \_\_\_\_\_  
 TYPE: \_\_\_\_\_

### DESCRIPTION

Medium base HPS, MH or CFL specification grade flood with Integra Hood glare shield.  
 Lamp supplied.

### SPECIFICATIONS

#### Finish:

Chip and fade resistant polyester powder coating

#### Ground Mounting:

Use the new MPM19 Mighty Post with aluminum cap for sturdy installation

#### Housing:

Precision die cast aluminum. 1/2" NPS locking Swivel Arm, Wall Bracket Trunnion or Slip Fitter

#### Lens Frame & Glare Shield:

Precision die cast aluminum. Hinged for easy access. Phillips head screws for added security

#### Lens Gasket:

High temperature one piece molded silicone set in die cast retaining groove. Remains in place during relamping

#### Lens:

Thermal tempered shock resistant glass, 3/16" thick

#### Reflector:

Anodized aluminum. Field adjustable beam spread. Rotates 90° for horizontal or vertical lamp position

#### Socket:

HID: Porcelain 4kv Pulse Rated socket with nickel plated screw shell CFL: Plug in type, GX24q-4 base

#### UL Listing:

Suitable for wet locations. Suitable for mounting within 4' of the ground

#### EPA:

Maximum EPA: 1.1

#### Patents:

Pat. D545,472

#### Quad Tap:

Fixture works with 120, 208, 240 and 277 Volts

#### Color:

Bronze

#### Weight:

16.3

### DIMENSIONS

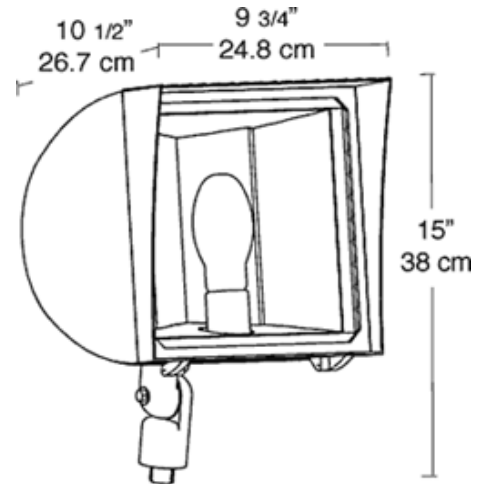

### PHOTOMETRIC

175w Metal Halide @ 10' Mounting Height  
 Aimed 30° below horizontal.

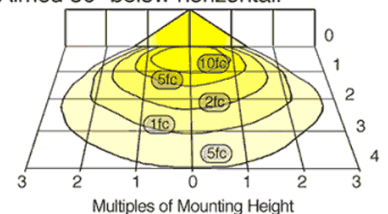

Mounting Height	Multiplier	Multiplier		
		Watts	HPS	MH CFL
8'	1.6	175		1.0
10'	1.0	150PS		1.0
12'	.7	150	1.2	1.0
16'	.4	100	.7	.7
20'	.25	70	.5	.4
		50	.3	.25
		42		.23

### ORDERING INFORMATION

**High Pressure Sodium**  
 Lamp supplied with fixture

Total Watts	Lamp Type	Lamp Base	Ballast
150	ED17	Medium	HX-HPF QT

Starting Amps/ Operating Amps			
120V	208V	240V	277V
2.0/1.7	1.2/1.0	1/1.9	.9/.8

Input Watts	LAMP ANSI	Initial Lumens		Lamp Hours
		HPS	MH	
188	S55	16000	24000	

**Factory Installed Options**  
 Add suffix to Catalog Number

Swivel Photocontrol wired for 120V (/PCS)  
 Single fusing for 120 and 277 volt (/F)

Double fusing for 208 and 240 volt (/FF)  
 Button Photocontrol wired for 120V (/PC)

Note: Specifications may change without notice