

PowPak® 20 A Relay Module

The PowPak® 20 A Relay Module is a radio-frequency (RF), receptacle switching solution that is capable of controlling 20 A receptacles based on input from Pico® wireless controls and Radio Powr Savr™ occupancy sensors.

Communication with RF input devices, such as Pico® wireless controls and/or Radio Powr Savr™ occupancy/vacancy sensors, is accomplished using Lutron® Clear Connect® RF Technology. Receptacle load control is provided using technology from Hubbell Wiring Device - Kellems.

Features

- Able to control 20 A receptacles
- Wide operating voltage: 120–277 V~
- Capable of switching general-purpose loads
- Receives wireless inputs from a total of ten wireless controls maximum (Pico® wireless controls or Radio Powr Savr™ occupancy/vacancy sensors)
- Utilizes Lutron® Clear Connect® RF Technology
- Mounts to a U.S. style junction box through a standard size knockout
- Heavy duty mechanically held, latching relays, with silver alloy contacts
- UL®/cUL listed
- Zero cross switching
- Includes required controlled outlet labels for code compliance
- Provides a fail safe mechanism to turn on the output in the event of a missing sensor
- BAA compliant

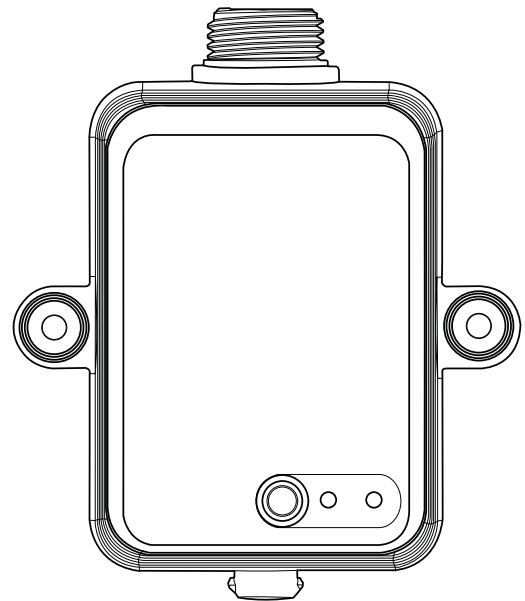

RMJ-H20R-DV-B

Model Numbers

Description	Model Number	Region	Operating Voltage	Frequency Band
PowPak® 20 A Relay Module	RMJ-H20R-DV-B	U.S.A., Canada (BAA compliant)	120–277 V~	431.0–437.0 MHz

Job Name:	Model Numbers:
Job Number:	

Specifications

Regulatory Approvals

- Complies with requirements for use in other spaces used for environmental air (plenums) per NEC® 2014 300.22(C)(3)
- UL® Listed (USA)
- FCC approved. Complies with the limits for a Class B device, pursuant to Part 15 of the FCC rules. (USA)
- cUL® and IC (Canada)

Power

- Operating voltage: 120–277 V~ 50/60 Hz
- Standby Power Consumption (all models): < 1.25 W

System Communication

- Operates using Clear Connect® RF Technology for reliable wireless communication.
- RF range is 30 ft (9 m)
- Contact Lutron first for applications using foil-backed or metallic ceiling tiles.

Environment

- Ambient operating temperature: 32 °F to 104 °F (0 °C to 40 °C)
- 0% to 90% humidity, non-condensing
- For indoor use only

Load

- 20 A; No minimum load requirements.
- Load types include (but are not limited to): Incandescent, MLV, ELV, Resistive, Inductive
- Motor rating: 1.0 HP (120 V~), 2.0 HP (240–277 V~)
- Able to control 20 A receptacles
- The 20 A Relay Module may be used with, but is not limited to, the following:
 - Monitors
 - Fans
 - Humidifiers
 - Printers

Note: Refer to the manufacturer’s guidelines for acceptable switching methods.

- The 20 A Relay Module may NOT be suitable for use with devices that require any of the following:
 - Shut-down process before power is interrupted, such as computers.
 - Cool-down process before power is interrupted, such as projectors.
 - Programming, such as clocks or DVRs.
 - Long warm-up cycle.
- **Not for use with loads that present a hazard if automatically energized. For example, heaters.**
- **Any receptacles that are controlled by an automatic control device must be marked with “⏻” located on the controlled receptacle outlet where visible after installation as stated in 2014 NEC® Article 406.3(E).**

Key Design Features

- LED status indicator shows current load status and provides programming feedback
- Power failure memory: If power is interrupted, connected receptacles will return to the state prior to the power interruption.
- Zero cross switching
- Heavy-duty relays

<p>Job Name:</p> <p>Job Number:</p>	<p>Model Numbers:</p>
--	-----------------------

Dimensions

Dimensions are shown as: in (mm)

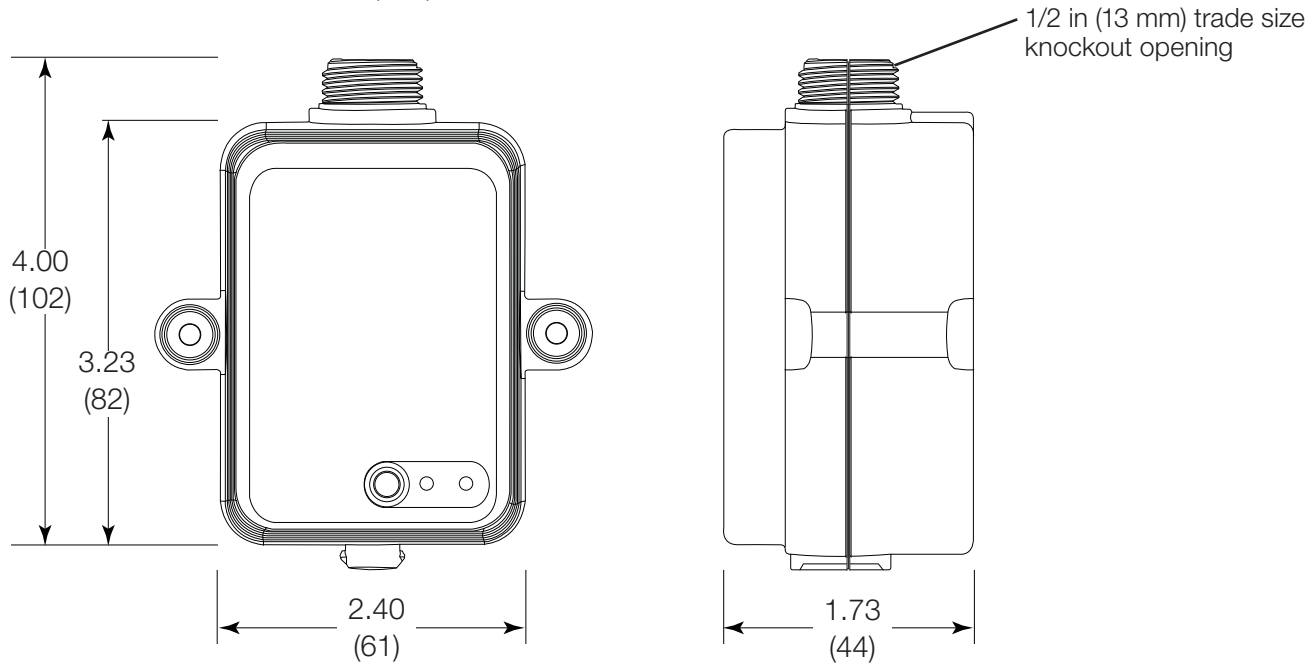

Range Diagrams

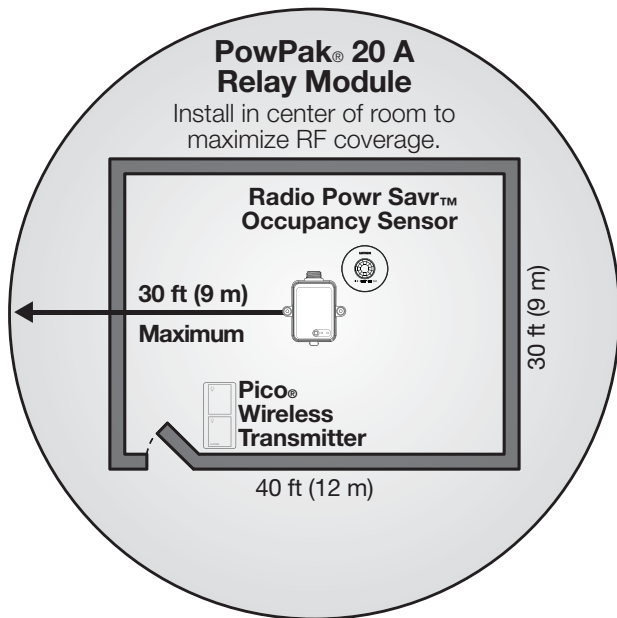

All Wireless Transmitters must be installed within 30 ft (9 m) of the PowPak® 20 A Relay Module.

- Contact Lutron first for applications using foil-backed or metallic ceiling tiles.

Job Name:	Model Numbers:
Job Number:	

System Diagram

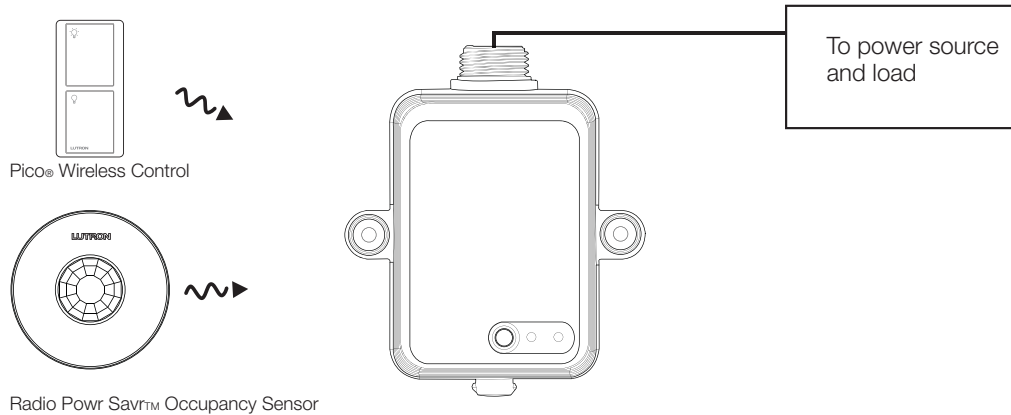

* Total of ten wireless devices maximum

Default Operation

Transmitting Device	Transmitted Command	Relay Default Action
Pico® Wireless Control	On	Close
	Off	Open
	Raise	No Action
	Lower	No Action
	Preset	Close
Radio Powr Savr™ Occupancy Sensor	Occupied	Close
	Unoccupied	Open
Radio Powr Savr™ Vacancy Sensor	Occupied	Close
	Unoccupied	Open

Note: Unaffected Mode allows a system with an Occupancy sensor associated to multiple relay modules to be set up such that only selected loads turn on automatically. Other loads will require a manual turn-on with a Pico® wireless control. All loads will turn off automatically when the room is vacated. See the PowPak® 20 A Relay Module installation guide for more information on Unaffected Mode.

Job Name:	Model Numbers:
Job Number:	

Wiring Diagram - for Duplex Receptacle

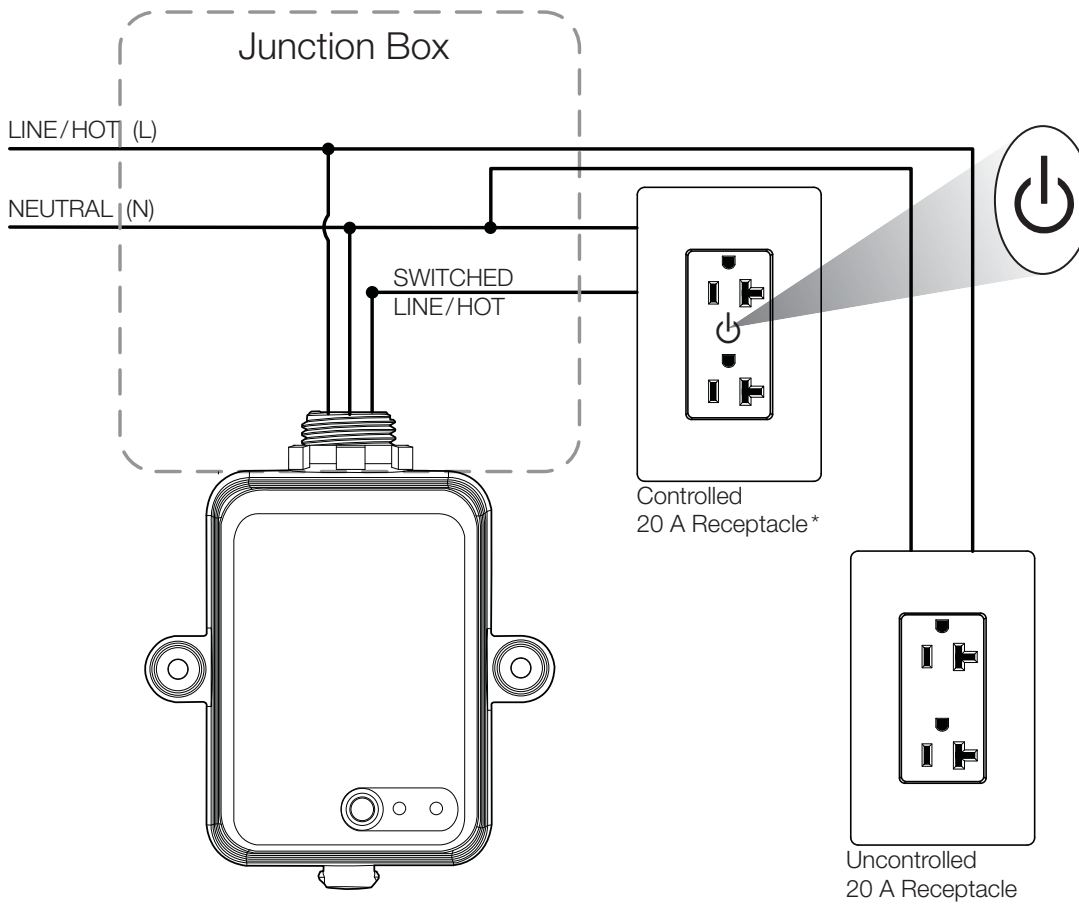

ATTENTION INSTALLER

Any receptacles that are controlled by an automatic control device must be marked with “⏻” located on the controlled receptacle outlet where visible after installation as stated in 2014 NEC® Article 406.3(E).

Note: The 20 A Relay Module is also capable of controlling 120–277 V~ lighting and receptacles. Receptacle wiring diagram shown.

*** Important Note**



WARNING - Entrapment/Fire Hazard - To avoid the risk of entrapment, serious injury, or death, these controls must not be used to control equipment which is not visible from every control location or which could create hazardous situations such as entrapment if operated accidentally. Examples of such equipment which must not be operated by these controls include (but are not limited to) motorized gates, industrial doors, space heaters, etc. It is the installer’s responsibility to ensure that the equipment being controlled is visible from every control location and that only suitable equipment is connected to these controls. Failure to do so could result in serious injury or death.

Job Name:	Model Numbers:
Job Number:	

Wiring Diagram - for Split-Wired Duplex Receptacle

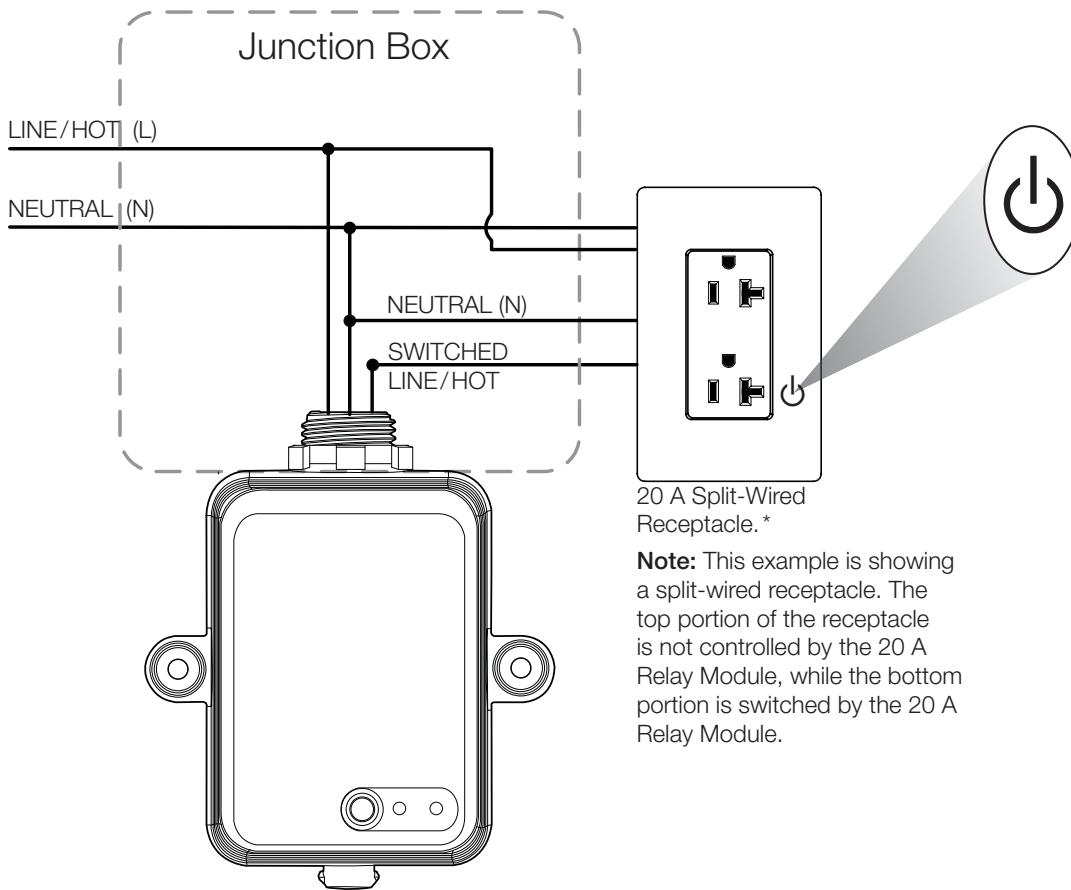

ATTENTION INSTALLER

Any receptacles that are controlled by an automatic control device must be marked with “⏻” located on the controlled receptacle outlet where visible after installation as stated in 2014 NEC® Article 406.3(E).

20 A Split-Wired Receptacle.*

Note: This example is showing a split-wired receptacle. The top portion of the receptacle is not controlled by the 20 A Relay Module, while the bottom portion is switched by the 20 A Relay Module.

Note: The 20 A Relay Module is also capable of controlling 120–277 V~ lighting and receptacles. Receptacle wiring diagram shown.

* Important Note



WARNING - Entrapment/Fire Hazard - To avoid the risk of entrapment, serious injury, or death, these controls must not be used to control equipment which is not visible from every control location or which could create hazardous situations such as entrapment if operated accidentally. Examples of such equipment which must not be operated by these controls include (but are not limited to) motorized gates, industrial doors, space heaters, etc. It is the installer’s responsibility to ensure that the equipment being controlled is visible from every control location and that only suitable equipment is connected to these controls. Failure to do so could result in serious injury or death.

Job Name:	Model Numbers:
Job Number:	