





**READ AND FOLLOW ALL SAFETY INSTRUCTIONS!
SAVE THESE INSTRUCTIONS AND DELIVER TO OWNER AFTER INSTALLATION**

- To reduce the risk of death, personal injury or property damage from fire, electric shock, falling parts, cuts/abrasions, and other hazards please read all warnings and instructions included with and on the fixture box and all fixture labels.
- Before installing, servicing, or performing routine maintenance upon this equipment, follow these general precautions.
- Installation and service of luminaires should be performed by a **qualified licensed electrician**.
- Maintenance of the luminaires should be performed by person(s) familiar with the luminaires' construction and operation and any hazards involved. Regular fixture maintenance programs are recommended.
- It will occasionally be necessary to clean the outside of the refractor/lens. Frequency of cleaning will depend on ambient dirt level and minimum light output which is acceptable to user. Refractor/lens should be washed in a solution of warm water and any mild, non-abrasive household detergent, rinsed with clean water and wiped dry. Should optical assembly become dirty on the inside, wipe refractor/lens and clean in above manner, replacing damaged gaskets as necessary.
- **DO NOT INSTALL DAMAGED PRODUCT!** This luminaire has been properly packed so that no parts should have been damaged during transit. Inspect to confirm. Any part damaged or broken during or after assembly should be replaced.
- Recycle: For information on how to recycle LED electronic products, please visit www.epa.gov.
- These instructions do not purport to cover all details or variations in equipment nor to provide every possible contingency to meet in connection with installation, operation, or maintenance. Should further information be desired or should particular problems arise which are not covered sufficiently for the purchaser's or owner's purposes, this matter should be referred to Acuity Brands Lighting, Inc.

<div style="display: flex; align-items: center; justify-content: center;">  <div style="border: 1px solid black; padding: 5px; text-align: center;"> <p>WARNING RISK OF ELECTRIC SHOCK</p> </div> </div> <ul style="list-style-type: none"> ✓ Disconnect or turn off power before installation or servicing. ✓ Verify that supply voltage is correct by comparing it with the luminaire label information. ✓ Make all electrical and grounded connections in accordance with the National Electrical Code (NEC) and any applicable local code requirements. ✓ All wiring connections should be capped with UL approved recognized wire connectors. 	<div style="display: flex; align-items: center; justify-content: center;">  <div style="border: 1px solid black; padding: 5px; text-align: center;"> <p>WARNING RISK OF BURN</p> </div> </div> <ul style="list-style-type: none"> ✓ Allow lamp/fixture to cool before handling. Do not touch enclosure or light source. ✓ Do not exceed maximum wattage marked on luminaire label. ✓ Follow all manufacturer's warnings, recommendations and restrictions for: driver type, burning position, mounting locations/methods, replacement and recycling.
<div style="display: flex; align-items: center; justify-content: center;">  <div style="border: 1px solid black; padding: 5px; text-align: center;"> <p>CAUTION RISK OF INJURY</p> </div> </div> <ul style="list-style-type: none"> ✓ Wear gloves and safety glasses at all times when removing luminaire from carton, installing, servicing or performing maintenance. ✓ Avoid direct eye exposure to the light source while it is on. 	<div style="display: flex; align-items: center; justify-content: center;">  <div style="border: 1px solid black; padding: 5px; text-align: center;"> <p>CAUTION RISK OF FIRE</p> </div> </div> <ul style="list-style-type: none"> ✓ Keep combustible and other materials that can burn, away from lamp/lens. ✓ Do not operate in close proximity to persons, combustible materials or substances affected by heat or drying.



CAUTION: RISK OF PRODUCT DAMAGE

- ✓ Never connect components under load.
- ✓ Do not mount or support these fixtures in a manner that can cut the outer jacket or damage wire insulation.
- ✓ Controls for dimming, auto-sensing, or remote control of a luminaire that are not factory-wired to the luminaire must be checked for compatibility with the luminaire prior to installation. LED fixtures must be powered directly off a switched circuit.
- ✓ Unless individual product specifications deem otherwise: Do not restrict fixture ventilation. Allow for some volume of airspace around fixture. Avoid covering LED fixtures with insulation, foam, or other material that will prevent convection or conduction cooling.
- ✓ Unless individual product specifications deem otherwise: Do not exceed fixtures maximum ambient temperature.
- ✓ Only use fixture in its intended location.
- ✓ LED products are Polarity Sensitive. Ensure proper Polarity before installation.
- ✓ Electrostatic Discharge (ESD): ESD can damage LED fixtures. Personal grounding equipment must be worn during all installation or servicing of the unit.
- ✓ Do not touch individual electrical components as this can cause ESD, shorten lamp life, or alter performance.
- ✓ Some components inside the fixture may not be serviceable. In the unlikely event your unit may require service, stop using the unit immediately and contact an ABL representative for assistance.
- ✓ Always read the fixtures complete installation instructions prior to installation for any additional fixture specific warnings.
- ✓ Always ensure that the electrical distribution system is up to NEC (and any applicable local code) requirements.
- ✓ Verify that power distribution system has proper grounding. Lack of proper earth ground can lead to fixture failure and may void warranty.

All luminaires that contain electronic devices that generate frequencies above 9kHz from any component within the luminaire comply with Part 15 of the FCC Rules. Operation is subject to the following two conditions:

- (1) This device may not cause harmful interference
- (2) This device must accept any interference received, including interference that may cause undesired operation

Failure to follow any of these instructions could void product warranties. For a complete listing of product Terms and Conditions, please visit www.acuitybrands.com.

Our Brands Lithonia Lighting Carandini Holophane RELOC Light Concepts	Indoor/Outdoor Lithonia Lighting Carandini Holophane RELOC Light Concepts	Indoor Lighting Gotham Mark Architectural Lighting Peerless Renaissance Lighting Winona Lighting	Outdoor Lighting American Electric Lighting Antique Street Lamps Hydrel Tersen	Controls DARK TO LIGHT LC&D ROAM Sensor Switch Synergy	Daylighting SunOptics
---	---	--	---	--	---------------------------------

Acuity Brands Lighting, Inc. assumes no responsibility for claims arising out of improper or careless installation or handling of its products.

ABL LED General Warnings, Form No. 503.203

© 2010, 2016 Acuity Brands Lighting, Inc. All rights reserved. 12/01/10

Class R Type II Retrofit Kit

Installation Instructions for Fixture Conversion Retrofit Classified by Underwriters Laboratories, Inc.

- Reflector Kit Type II :** Reflector installation or replacement.
Lamp holder relocation, removal, or replacement.
Ballast relocation, removal, replacement or addition.

Installation Instructions

This LED Retrofit Kit will consist of the following, depending on 4FT (MS1) option or 8FT (MS2) option.

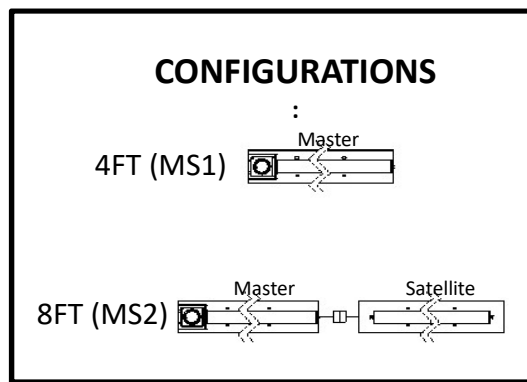

- (1) or (2) LED light panel(s) with quick connect wiring plug for supply connection (see page 5).

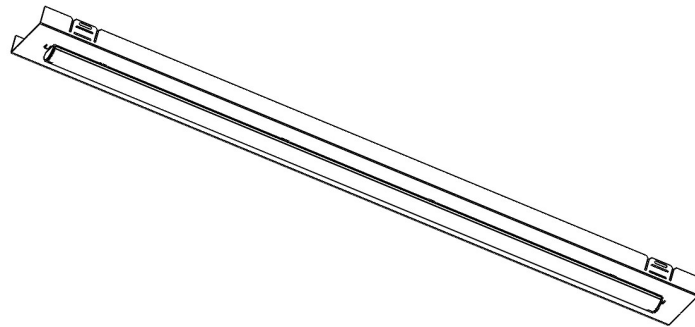

- (4) or (8) tek screws



WARNING: Risk of fire or electric shock. Luminaire wiring and electrical parts may be damaged when drilling for installation of LED Retrofit Kit. Check for enclosed wiring and components.

WARNING: Risk of fire or electric shock. Install this kit only in luminaires that have the construction features and dimensions shown in the photographs and/or drawings and where the input rating of the LED Retrofit Kit does not exceed the input rating of the luminaire.

WARNING: To prevent wiring damage or abrasion, do not expose wiring to edges of sheet metal or other sharp objects.

*** Locate the fluorescent lighting fixture that is to be retrofitted. **Turn off power.**

WARNING: Electrical shock can occur during retrofit component installation if power is not turned off.

WARNING: Risk of fire or electric shock. LED Retrofit Kit installation requires knowledge of luminaires electrical systems. If not qualified, do not attempt installation. Contact a qualified electrician.

WARNING: Unless otherwise indicated, do not make or alter any opening in the compartment of wiring or electrical components during installation of this retrofit assembly.

WARNING: Ensure that existing fixture is and remains properly connected to building ground. Use of any other than Acuity Brands Lighting supplied screws to install assembly may result in ungrounded fixture components.

For cUL units, THE RETROFIT KIT IS ACCEPTABLE AS A COMPONENT OF A LUMINAIRE WHERE THE SUITABILITY OF THE COMBINATION SHALL BE DETERMINED BY CSA OR AUTHORITIES HAVING JURISDICTION

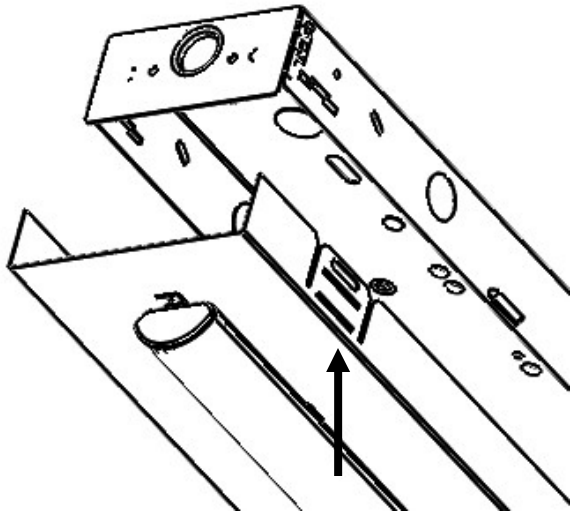

Step 1:

- Remove ballast cover, lamps, lamp brackets, lamp holders, and ballast from Host Fixture to provide adequate clearance for kit installation.
- Identify power supply wires to disconnect.
- Recycle or properly dispose of all components removed from Host Fixture.

Step 2:

- (left) Use Host Fixture to align Integrated Mounting Brackets and fold over sides as per host housing width. (Note the stamped channel size markings to ensure the brackets are folded appropriately and the LED Retrofit Kit is centered on the Host Fixture.)

Step 3:

- Make wire connections to supply power by connecting the black and white AC mains into the Supply Wire Quick Connect on the input side of the driver. Be sure to secure ground ring-terminal to fixture.

WIRING DIAGRAM

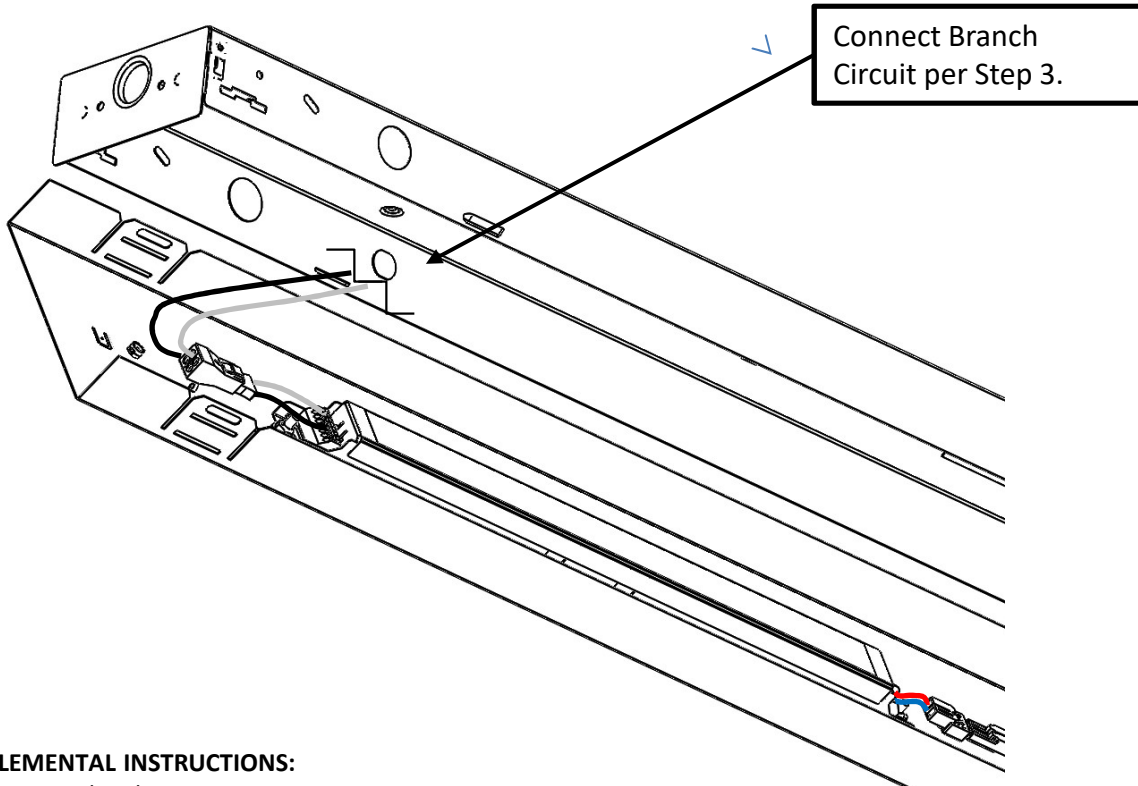
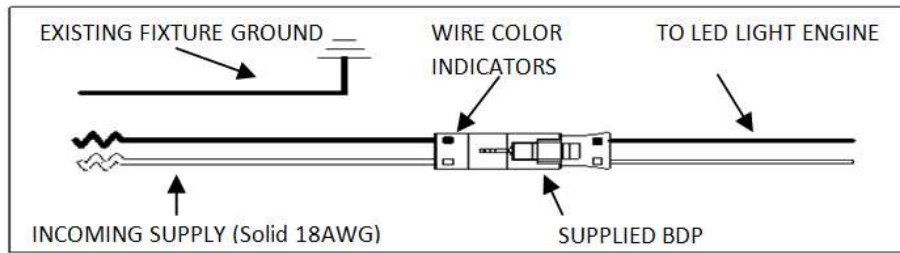

SUPPLEMENTAL INSTRUCTIONS:

- If optioned with Emergency Battery Back up, connect the test switch harness (bottom right) to the battery back up prior to installing LED retrofit kit to Host Fixture.
- Test switch will light RED when battery is charging.

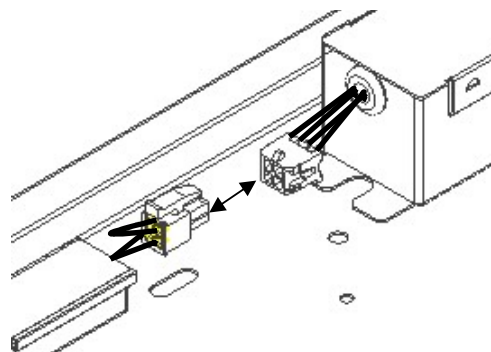

Step 4:

- Move LED Retrofit Kit into position.

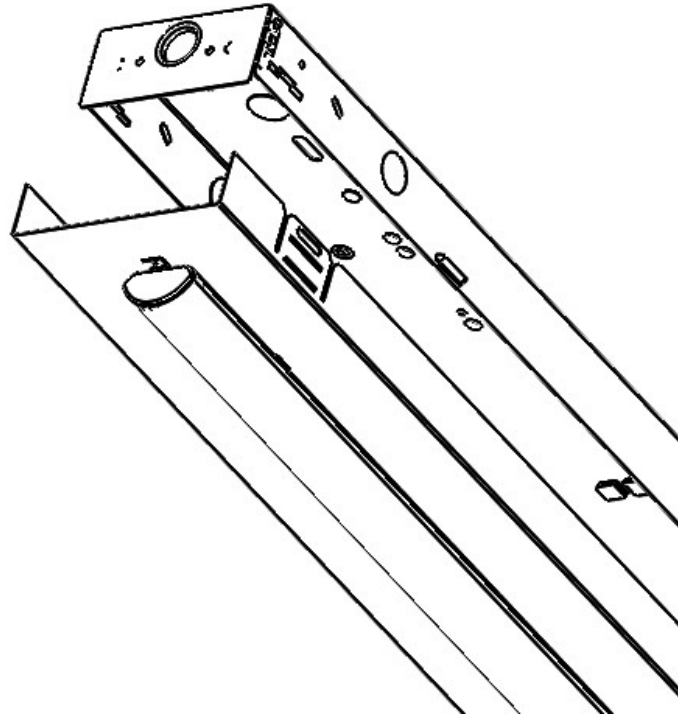

- Install using provided tek screws through mounting bracket, as shown.

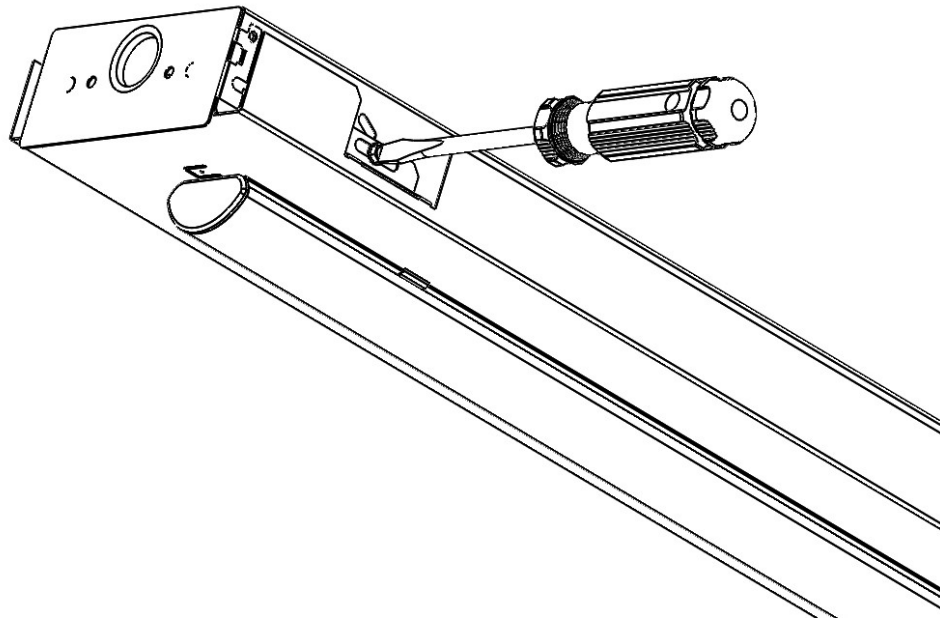

Note: If only installing a single 4FT unit (MS1), instruction ends here. If installing two units in-line 8FT unit (MS2), instruction continues.

Step 5:

- When installing two units in-line (8FT – MS2), connections must be made between kits. Each kit will have a wire lead with a disconnect, approx. 12” in length to connect to the next kit in line, as shown.
- There are two types of disconnects that could be encountered, as shown. Both have male and female counterparts, and kits can only be connected in one orientation.

Supplemental Instructions:

How to make a starter harness when equipped with PLR1LVG:

To power multiple units in-line, cut off female connector on PLR1LVG harness at location of power drop, strip the cut-end 3/8”, and wire-tie to line voltage. **BE SURE TO CAP ALL CONNECTIONS WHICH ARE UNUSED.**

Sensor Grouping:

- Only 10 drivers should be wired to any one sensor. The kit with an embedded sensor contains one driver pre-wired.

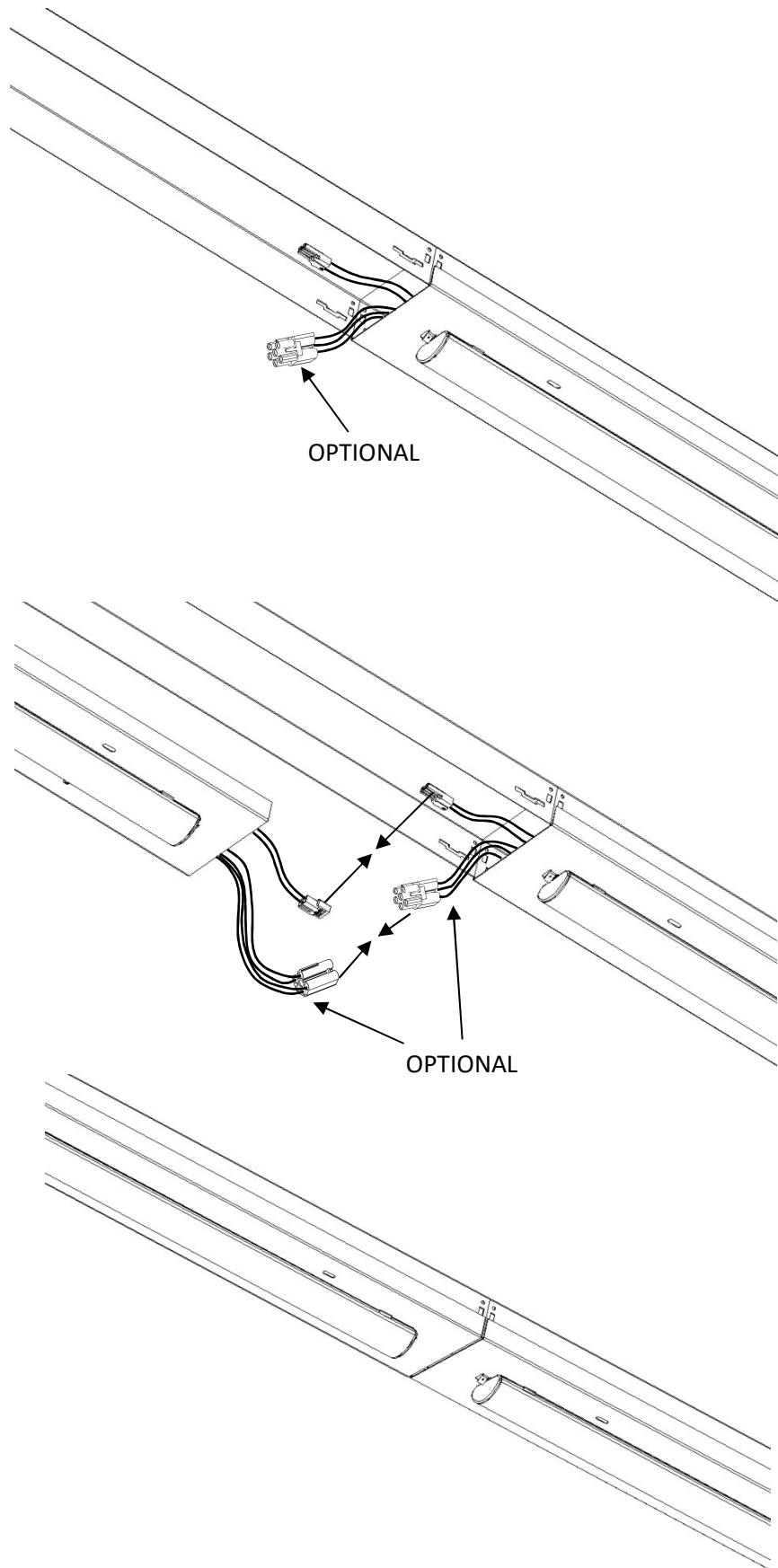

CONFIGURATIONS:

