

Instructions for T271L Lens Replacement

WARNING: For your safety, read and understand instructions completely before starting installation. Before wiring to power supply, turn off electricity at the fuse or circuit breaker box.

Note: Use with non-Juno fixtures voids Juno warranty.

SAVE THESE INSTRUCTIONS

Installation Instructions

- Step 1.** Remove the T271L fixture from the trac and place it face up as shown in (Figure 1).
- Step 2.** Grasp the lens retaining ring as shown in (Figure 1), away from the locking dimples.
- Step 3.** Rotate the lens retaining ring about 1/8 turn counterclockwise and remove.
- Step 4.** Note the position and orientation of the part number tab on the original lens as shown in (Figure 2).
- Step 5.** Carefully remove the original lens and replace with the accessory lens, installing it with the part number tab in the same orientation as the original lens. **DO NOT TOUCH EITHER FLAT SURFACE OF THE LENS AS SCRATCHES AND FINGERPRINTS MAY ALTER ITS PERFORMANCE.**
- Step 6.** Replace the lens retaining ring, again grasping it away from the locking dimples. Rotate the lens retaining ring about 1/8 turn clockwise until it clicks into place.

Figure 1

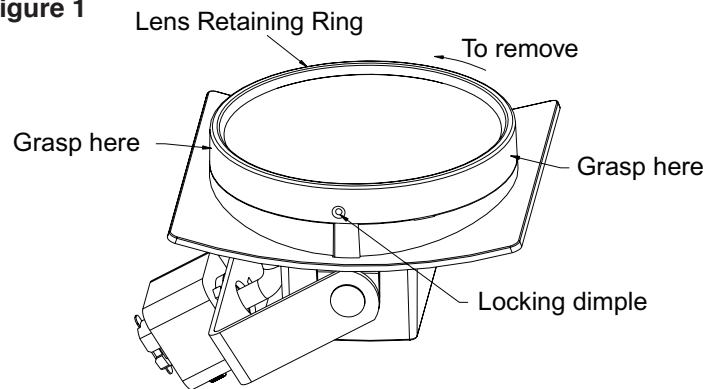
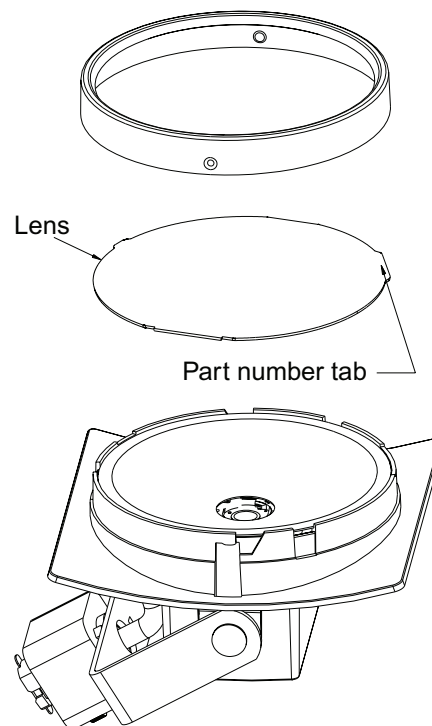

Figure 2



Instructions for T271L Cube Cell Louver/Lens Holder

WARNING: For your safety, read and understand instructions completely before starting installation. Before wiring to power supply, turn off electricity at the fuse or circuit breaker box.

Note: Use with non-Juno fixtures voids Juno warranty.

SAVE THESE INSTRUCTIONS

Installation Instructions

- Step 1.** Remove the T271L fixture from the trac and place it face up as shown in (Figure 1).
- Step 2.** Grasp the lens retaining ring as shown in (Figure 1), away from the locking dimples.
- Step 3.** Rotate the lens retaining ring about 1/8 turn counterclockwise and remove.
- Step 4.** Grasp the cube cell louver/lens holder away from the locking dimples. Rotate the cube cell louver/lens holder about 1/8 turn clockwise until it clicks into place.

Figure 1

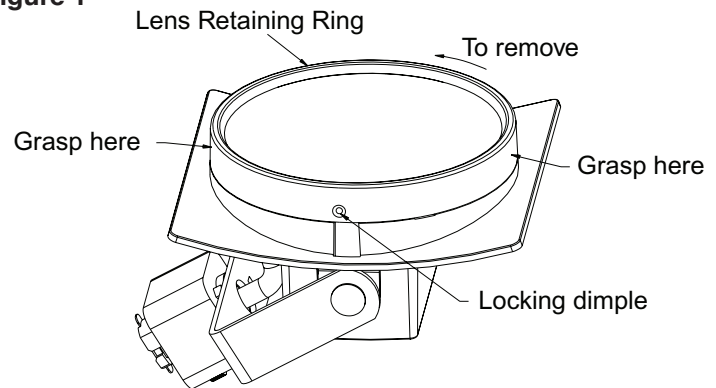

Cube Cell Louver/Lens Holder

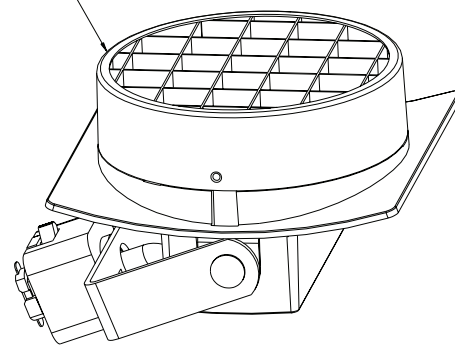

WARRANTY

Juno Lighting, LLC and its subsidiary companies, collectively Juno Lighting Group (JLG), warrants for the applicable Warranty Period below that products made by it and sold through its authorized sales channels are free from defects in material and workmanship. In the event of any defect, JLG's sole obligation is expressly limited to repair or replacement, without charge, at JLG's factory after prior written return authorization has been granted. This Warranty shall not apply to products which have been altered, improperly used, or repaired outside of JLG's factory nor shall it apply to defects for which written notification thereof is not received by JLG within the applicable Warranty Period. The Warranty Period for all JLG Trac Lighting products is one (1) year from date of purchase, except as follows: The Warranty Period for LED general lighting products is five (5) years from date of purchase.

THIS WARRANTY IS IN LIEU OF ALL OTHER WARRANTIES, EXPRESSED OR IMPLIED, AND WITHOUT EXCLUDING THE GENERALITY OF THE FOREGOING, EXCLUDES ANY IMPLIED WARRANTY OF MERCHANTABILITY OR FITNESS FOR A PARTICULAR PURPOSE. SPECIFICATIONS SUBJECT TO CHANGE WITHOUT NOTICE.

The use of other company's (non-JLG) products or components (i.e. Trac lights, connectors, trims, etc.) in conjunction with JLG products may not be covered by UL classification, and could be hazardous. Such usage, whether covered by UL classification or not, automatically voids all JLG product warranties.

Product Services Phone (888) 387-2212

1300 South Wolf Road • Des Plaines, IL 60018
PHONE (847) 827-9880 • FAX (847) 827-2925 • www.junolightinggroup.com



JUNO LIGHTING GROUP
by Schneider Electric