



TRAC-LITES

Current Limiting Feeds For R Series Trac Systems

Project: _____

Fixture Type: _____

Location: _____

Contact/Phone: _____

PRODUCT DESCRIPTION

Juno Trac-Lites Current Limiting Feeds provide a simple solution for complying with stringent energy codes like ASHRAE 90.1 and California Title 24. Installed at every trac lighting feed location, these feeds employ supplementary current limiting circuit breakers which are designed to limit available wattage to lighting circuits to only that necessary to meet the lighting design criteria. Rather than lighting loads being calculated by the greater of maximum fixture wattage ratings or an arbitrary watts-per-foot multiplier, the Trac-Lites Current Limiting Feeds enable calculations to instead be made based on the rating of the supplementary breaker(s) installed in the feeds. Because they limit a circuit, not the lighting equipment itself, the Trac-Lites Current Limiting Feeds provide maximum flexibility to accommodate frequent lighting design modifications and layout changes, especially typical for retail spaces.



PRODUCT SPECIFICATIONS

Features Designed to be installed at every trac feed location, in place of a standard non-limiting feed • In-line feeds can be used to feed trac as one electrical circuit in both directions or as two separate circuits using two current limiters • Feed connector and current limiting circuit breaker are specified and ordered separately for maximum configuration flexibility • Not intended to be used as a primary circuit protector.

Mini End Feed Construction Surface mounting only – not intended to be installed over a j-box • T-bar compatible only when installed off-grid and fed directly • One 7/8" knockout for direct electrical feed connections • Includes ground terminal attachment screw • Injection molded polycarbonate cover attaches to mounting plate using tamper-resistant screws (screwdriver bit supplied with each mini end feed) • Mini end feed connector is permanently attached to trac using one-way screw.

End Feed Construction Heavy-duty 14 gauge (0.075 thick) die formed galvanized steel mounting plate • Surface or j-box mounting • T-bar compatible when fed directly • Mounting holes provided for j-box attachment • Center knockout enables feeding from j-box for simple wiring termination • Two 7/8" knockouts for direct electrical feed connections • Includes ground terminal attachment screw • Injection molded polycarbonate cover with tearout for 2-breaker installations • Cover attaches to mounting plate using tamper-resistant screws (screwdriver bit supplied with each mini end feed) • Feed connector is permanently attached to trac using one-way screw.

Finish Available in white, black, bronze or silver finishes
• Supplementary current limiting circuit breakers are ordered separately and can be specified in complementary finishes to match feed connector.

Supplementary Current Limiting Circuit Breakers Miniature single pole supplementary current limiters limit the current (wattage) that can be consumed on the trac section being fed • Utilizes hydraulic magnetic technology which provides accurate and reliable circuit protection even when exposed to extremely hot and/or cold application environments • Rated for 120VAC, 60Hz operation • Available in individual amperage ratings of 0.5A, 1A, 2A, 3A, 4A, 5A, 6A, 7A, 8A, 9A, 10A, 12A and 14A, selected based on actual lighting loads • Can be operated continuously at rated current • Specially designed to prevent nuisance tripping • Easily snaps into mounting plate without the use of tools • Leads wires provided for simplified installation • ON/OFF indication clearly identifies breaker status • Easily resettable in the event of an overcurrent situation • UL 1077, CSA 22.2 approved.

Labels UL and cUL Listed • Approved by the California Energy Commission to meet the requirements of Title 24 • Complies with ASHRAE 90.1 and IECC Section 805.5.1.4 for trac current limiting.

Product specifications subject to change without notice.

ORDERING INFORMATION

Electrical feeds are chosen based on application (end or in-line). Supplementary current limiters are chosen separately based on total wattage to be applied to the trac circuit. Feeds and current limiters are supplied separately and easily assembled by the installer.

Current Limiting Electrical Feeds

Catalog Number	Description	Trac Type	Finish
RCLFM11BL	Mini End Feed	1-Circuit	Black
RCLFM11WH	Mini End Feed	1-Circuit	White
RCLFM11SL	Mini End Feed	1-Circuit	Silver
RCLFM11BZ	Mini End Feed	1-Circuit	Bronze
RCLF11BL	End Feed	1-Circuit	Black
RCLF11WH	End Feed	1-Circuit	White
RCLF11SL	End Feed	1-Circuit	Silver
RCLF11BZ	End Feed	1-Circuit	Bronze
RCLF21BL	In-Line Feed	1-Circuit	Black
RCLF21WH	In-Line Feed	1-Circuit	White
RCLF21SL	In-Line Feed	1-Circuit	Silver
RCLF21BZ	In-Line Feed	1-Circuit	Bronze

Current Limiting Circuit Breakers

(order separately)

Catalog Number	Description	Wattage	Finish
TCL0.5BL	0.5A Current Limiter	60W	Black
TCL0.5WH	0.5A Current Limiter	60W	White
TCL1BL	1A Current Limiter	120W	Black
TCL1WH	1A Current Limiter	120W	White
TCL2BL	2A Current Limiter	240W	Black
TCL2WH	2A Current Limiter	240W	White
TCL3BL	3A Current Limiter	360W	Black
TCL3WH	3A Current Limiter	360W	White
TCL4BL	4A Current Limiter	480W	Black
TCL4WH	4A Current Limiter	480W	White
TCL5BL	5A Current Limiter	600W	Black
TCL5WH	5A Current Limiter	600W	White
TCL6BL	6A Current Limiter	720W	Black
TCL6WH	6A Current Limiter	720W	White
TCL7BL	7A Current Limiter	840W	Black
TCL7WH	7A Current Limiter	840W	White
TCL8BL	8A Current Limiter	960W	Black
TCL8WH	8A Current Limiter	960W	White
TCL9BL	9A Current Limiter	1080W	Black
TCL9WH	9A Current Limiter	1080W	White
TCL10BL	10A Current Limiter	1200W	Black
TCL10WH	10A Current Limiter	1200W	White
TCL12BL	12A Current Limiter	1440W	Black
TCL12WH	12A Current Limiter	1440W	White
TCL14BL	14A Current Limiter	1680W	Black
TCL14WH	14A Current Limiter	1680W	White

TRAC-LITES

Current Limiting Feeds

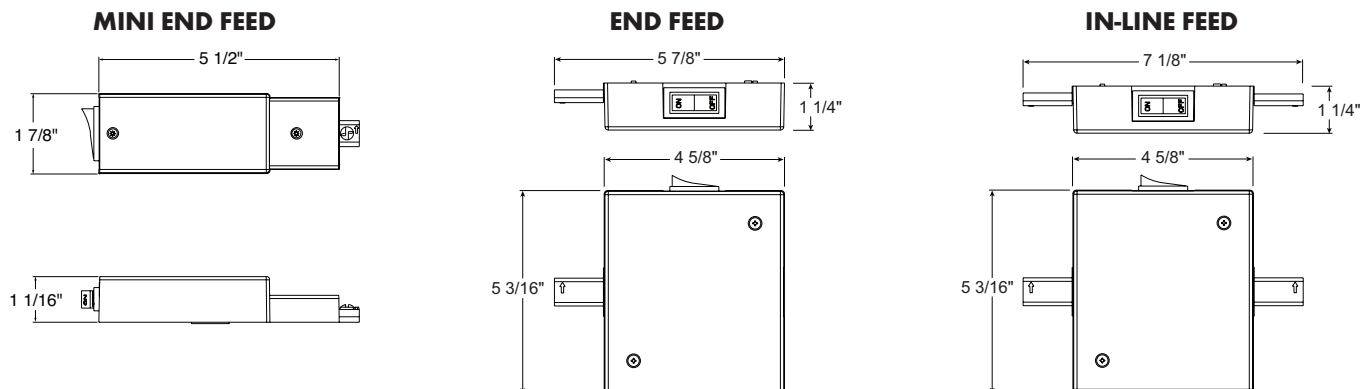

APPLICATION

Energy codes typically calculate trac lighting loads based on linear feet of installed trac. Some codes use an arbitrary multiplier as low as 30 watts/foot while others use a multiplier as high as 70 watts/foot. When using the energy efficient lighting technologies available today, the connected load is typically much less than the per-foot multipliers used by most energy codes. This penalizes lighting designs that employ trac lighting and wastes available lighting watts that could be used more effectively.

Below is a typical trac lighting example. The Standard Layout consists of 100' of single circuit trac (4 circuits x 25' each) with 32 LED trac heads, each consuming 24W, for a total connected load of 768W. The scenario with the *Trac-Lites* Current Limiting Feeds uses the original 100' of single circuit trac, with each 25' trac section monitored by a 2-Amp supplementary current limiter that is closely matched to the actual connected load of 768W plus a small buffer. This significantly reduces the calculated watts per the energy codes.

1. Standard Layout without Trac-Lites Current Limiting Feeds

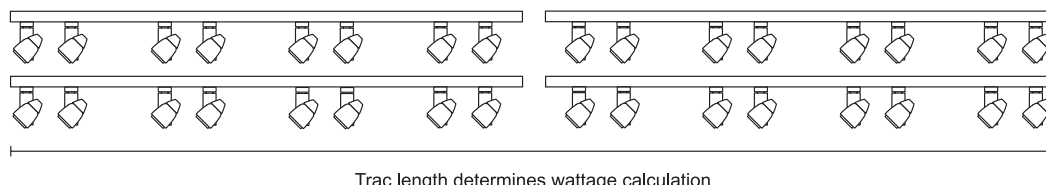

100 ft of track = **4500W***

*Based on 45W/ft multiplier of California Title 24

Trac-Lites Current Limiting Feeds install between the branch circuit breaker and the trac lighting, solving the energy code calculation discrepancy, making the wattage calculation independent of trac length.

3. Standard Layout with Trac-Lites Current Limiting Feeds

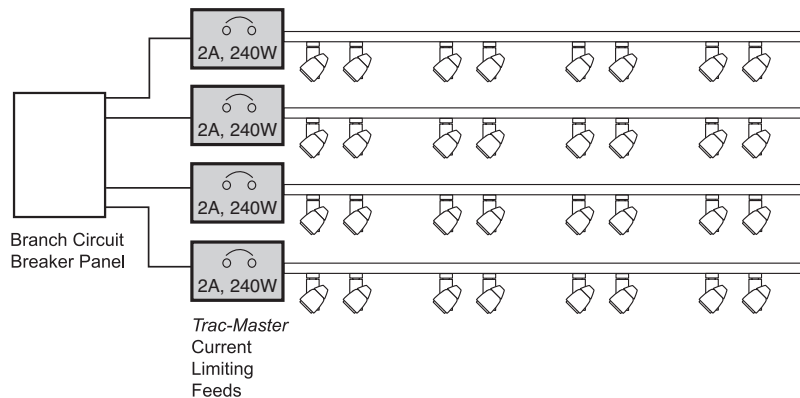

Same 100 ft. of trac: 2A @ 120V = 240W (x4 circuits)

960W total



1300 S. Wolf Road • Des Plaines, IL 60018 • Phone (847) 827-9880 • Fax (847) 827-2925
 220 Chrysler Drive • Brampton, Ontario • Canada L6S 6B6 • Phone (905) 792-7335 • Fax (905) 792-0064
 Visit us at www.junolightinggroup.com

Printed in U.S.A. ©2013 Juno Lighting, LLC.