

Installation Instructions

For Juno TLR36 Outlet Box/T-Bar Feed and TLR36TB Terminal Block Connector

Important Safety Instructions-Save these Instructions

1. Read all of these installation instructions before installing the trac system.
 2. Do not install this trac in damp or wet locations.
 3. Do not install any fixture assembly closer than 6" from any curtain or similar combustible material.
 4. Disconnect electrical power before adding to or changing the configuration of the trac.
 5. Do not attempt to energize anything other than lighting fixtures on the trac. To reduce the risk of fire or electrical shock, do not attempt to connect power tools, extension cords, appliances and the like to the trac.
 6. Power to this trac system is to be supplied by either Juno 12V transformers (TL544N, TL547 (remote mounted only), TL548, TL549, TL550, TL554, TF5150, TF5300, TF5300-277, TF5600, TF5600-277, TF6150E, TF6300) or 24V transformers (TL551, TL552, TL553, TF5600-24V, TF5600277-24V, TF51200-24V, TF51200277-24V). Check with a qualified electrician before wiring trac. If 25 amps is exceeded anywhere in the installed trac system, an overload will occur, resulting in a potential fire.
 7. The TLR36 is only to be used with Juno TLR series trac systems. Use only fixtures intended for use with Juno TL or TLR series trac.
 8. Save these instructions and refer to them when additions to or changes in the trac configuration are made.
-

NOTES:

** This low voltage trac lighting system must be wired in accordance to national and/or local codes using approved Class 1 wiring methods when applicable. Check with a qualified electrician before installing.

** All wire retaining set screws on terminal block connectors must be tightened to 12 to 18 in-lbs (1 to 1.5 ft-lbs) to ensure reliable and safe operation.

** The terminal block used on all Trac 12/25 (TLR series) feeds and connectors is compatible with a minimum of 18 AWG thru a maximum of 6 AWG solid or stranded wire. The use of any field-installed wire that does not fall within this range or is not suitable for the level of the transformer output voids the Juno warranty and poses a possible safety hazard.

WARRANTY

Juno warrants that its products are free from defects in material and workmanship. Juno's obligation is expressly limited to repair or replacement, without charge, at Juno's factory after prior written return authorization has been granted. This warranty shall not apply to products which have been altered or repaired outside of Juno's factory. This warranty is in lieu of all other warranties, express or implied, and without limiting the generality of the foregoing phrase, excludes any implied warranty of merchantability. Also, there are no warranties which extend beyond the description of the product on the company's literature setting forth terms of sale.

TLR36 Outlet Box/T-Bar Feed

Used to make an electrical connection to a low voltage remote mounted transformer. The TLR36 can mount to various junction boxes, a rigid ceiling, or a T-Bar ceiling (with TLR37 T-Bar mounting clip purchased separately). The TLR36 can be converted into an "L", "T", or "X" configuration to supply power to or connect multiple track sections in 4 different directions when used in conjunction with the TLR36TB Terminal Block Connector.

1. Remove connector cover by removing (2) cover screws
2. Loosen the (4) set screws in the terminal block to allow wire entry and loosen the pointed screw which fastens the connector to the trac.
3. Remove the terminal block from the mounting plate by loosening the #4 screw in the middle terminal block hole.
4. Refer to figure 1 on Page 3 to determine how the plate is fastened in each corresponding application (mounting hardware not included). Take note of how the screws secure the plate for each different application. In some instances, the plate has to be slightly shifted right or left, and will not fall on the center of the electrical box.
5. Determine which knockout in the mounting plate will best allow wire entry into the connector wiring compartment (electrical box mounting) or 1/2" electrical fitting (T-Bar and rigid ceiling mounting). Remove chosen knockout using a standard flat blade screwdriver. Eliminate any burrs or sharp areas where the knockout was removed to prevent wire damage. Pull 6" of the transformer secondary wires into the wiring compartment (tighten electrical fitting if applicable). Place the mounting plate over the electrical box, rigid surface, or T-bar ceiling as outlined in step 4, and secure.
6. Strip 5/16" of insulation from both transformer secondary wires and insert into the terminal block opening opposite the pointed screw. Tighten the (2) set screws retaining the wires until snug.
7. Select which direction the track will run, and fasten the terminal block to the appropriate mounting form on the mounting plate with the #4 screw removed in step 3 (the pointed screw is to face towards the outside of the mounting plate).
8. Verify the trac has from 3/8"-7/16" of buss wire extending past the end. Slide the trac towards the terminal block, aligning the buss wires with the terminal block openings. Slide trac until it butts against the terminal block, hold firmly together, and tighten the pointed screw until snug.
9. Fully secure the trac to the corresponding mounting surface.
10. To make electrical connection to the buss, tighten the (2) set screws closest to the trac to 12 to 18 in-lb (1 to 1.5 ft-lb). Tighten the set screws retaining the transformer wires to 12 to 18 in-lb.
11. Place cover over trac & mounting plate assembly and secure mounting to plate with the (2) cover screws removed in step 1.

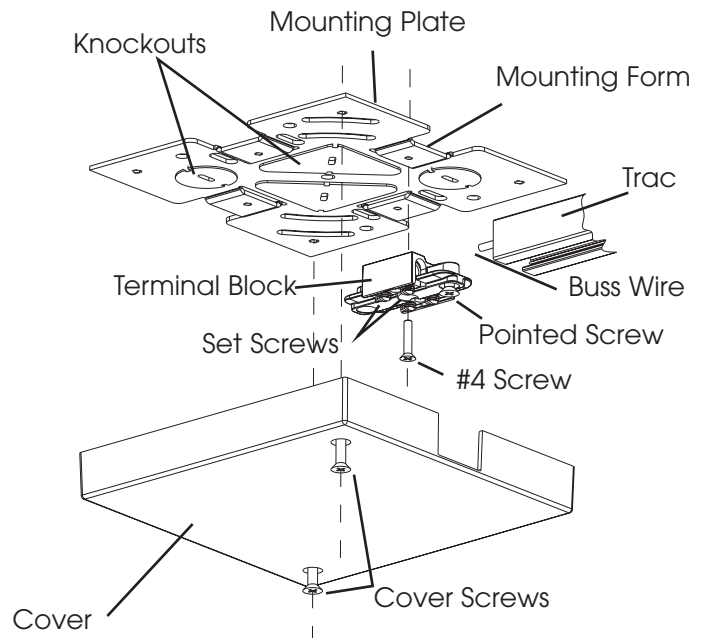

TLR36

Figure 1

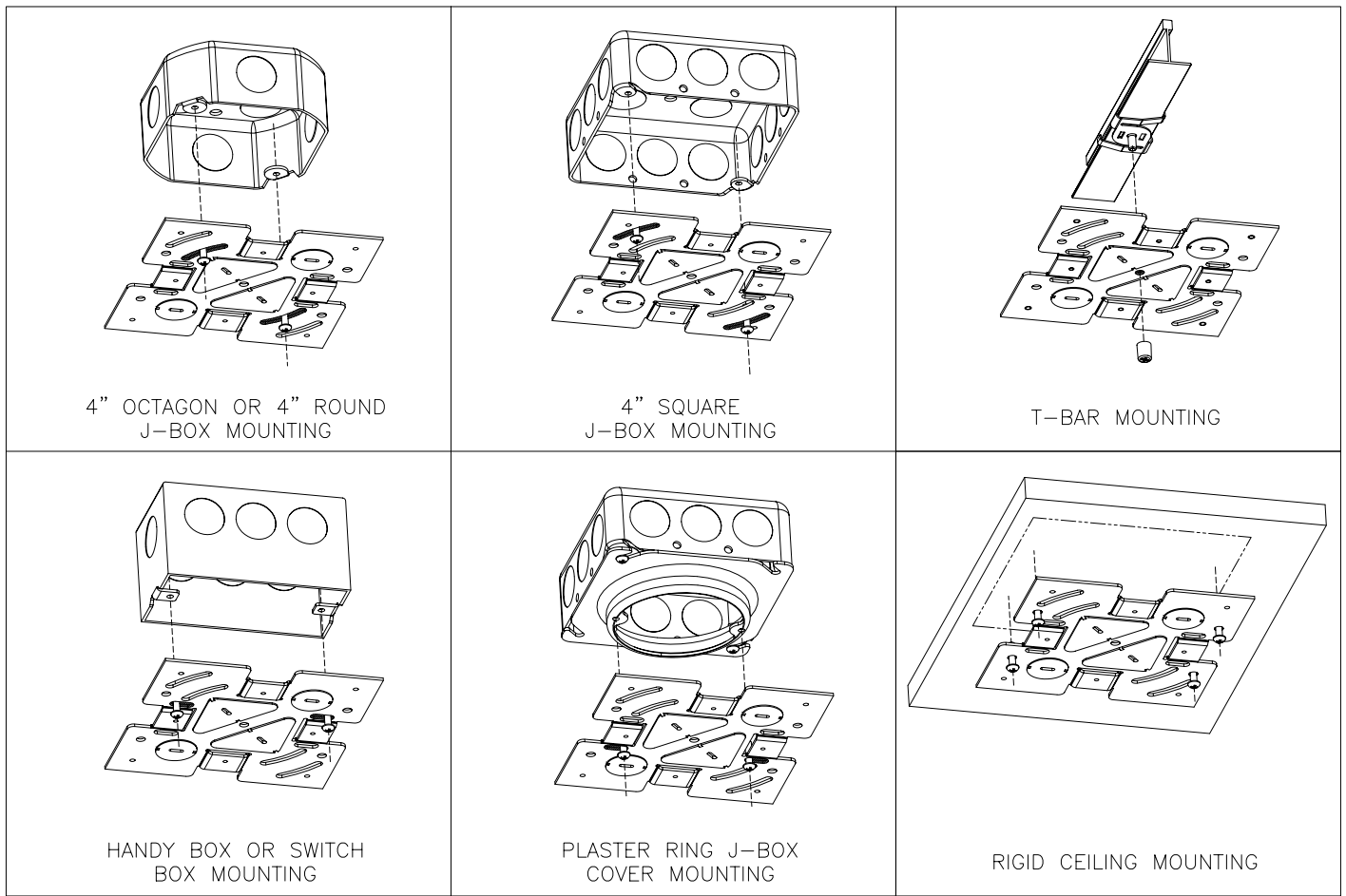

TLR36TB Terminal Block Connector

Used in conjunction with the TLR36. The TLR36TB can be used to convert the TLR36 into an “L”, “T”, or “X” connector (continue the trac run in various directions) and/or an additional feed point to power a run of trac from another transformer.

WARNING - RISK OF FIRE AND ELECTRIC SHOCK. THIS PRODUCT REQUIRES PROPER FIELD WIRING AND IS INTENDED TO BE INSTALLED BY A QUALIFIED ELECTRICIAN ONLY.

-See illustration on Page 4-

1. Remove the TLR36 cover by removing the (2) cover screws.
2. Determine the desired direction the trac will be expanded to, and screw the TLR36TB to the appropriate mounting form on the mounting plate with the supplied #4 screw (installed in the middle terminal block hole). Make sure the pointed screw in the terminal block is pointed towards the outside of the mounting plate. Repeat if expanding in more than 1 direction.
3. Loosen the (4) set screws in each TLR36TB Terminal Block Connector to allow wire entry, and loosen the pointed screw which fastens the connector to the trac.
4. Make electrical connections between terminal blocks in accordance to the wiring diagrams in figure 2 on page 4 using field supplied wiring that is suitable for the transformer output, and is in accordance with National & Local Electrical Codes. For wiring configurations not shown, please consult factory.
5. Tighten all set screws retaining the field installed wiring to 12 to 18 in-lb (1 to 1.5 ft-lb).
6. Verify the trac section being added has from 3/8”-7/16” of buss wire extending past the end. Slide the trac towards the terminal block, aligning the buss wires with the terminal block openings. Slide trac until it butts against the terminal block, hold firmly together, and tighten the pointed screw until snug. Fully secure the trac to the corresponding mounting surface, tighten the (2) set screws closest to the trac to 12 to 18 in-lb (1 to 1.5 ft-lb), and repeat for each additional trac section.
7. Determine which breakaway tab(s) in the cover have to be removed based on the TLR36TB installed locations. Grasp the tab firmly with pliers in between the 2 grooves. Holding the opposite side of the cover for support, bend the tab towards the outside of the cover in a quick, firm motion to ensure a clean “break”.
8. Place cover back over the trac & mounting plate assembly and secure to mounting plate with the (2) cover screws removed in step 1.

TLR36TB

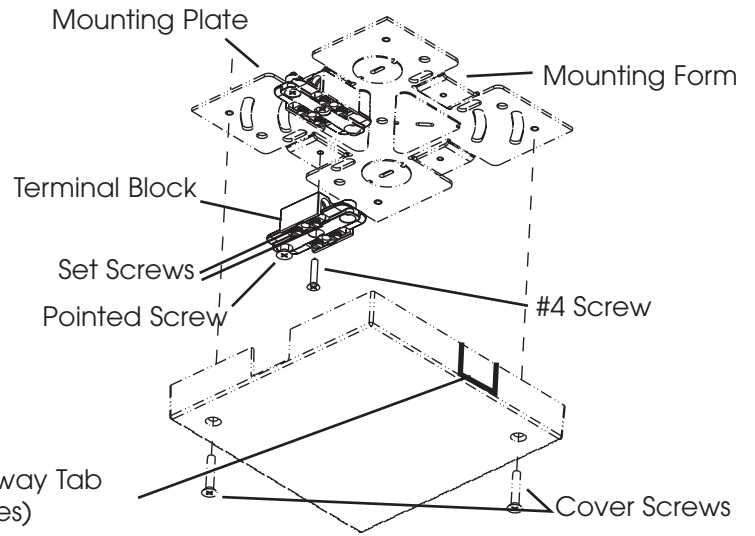
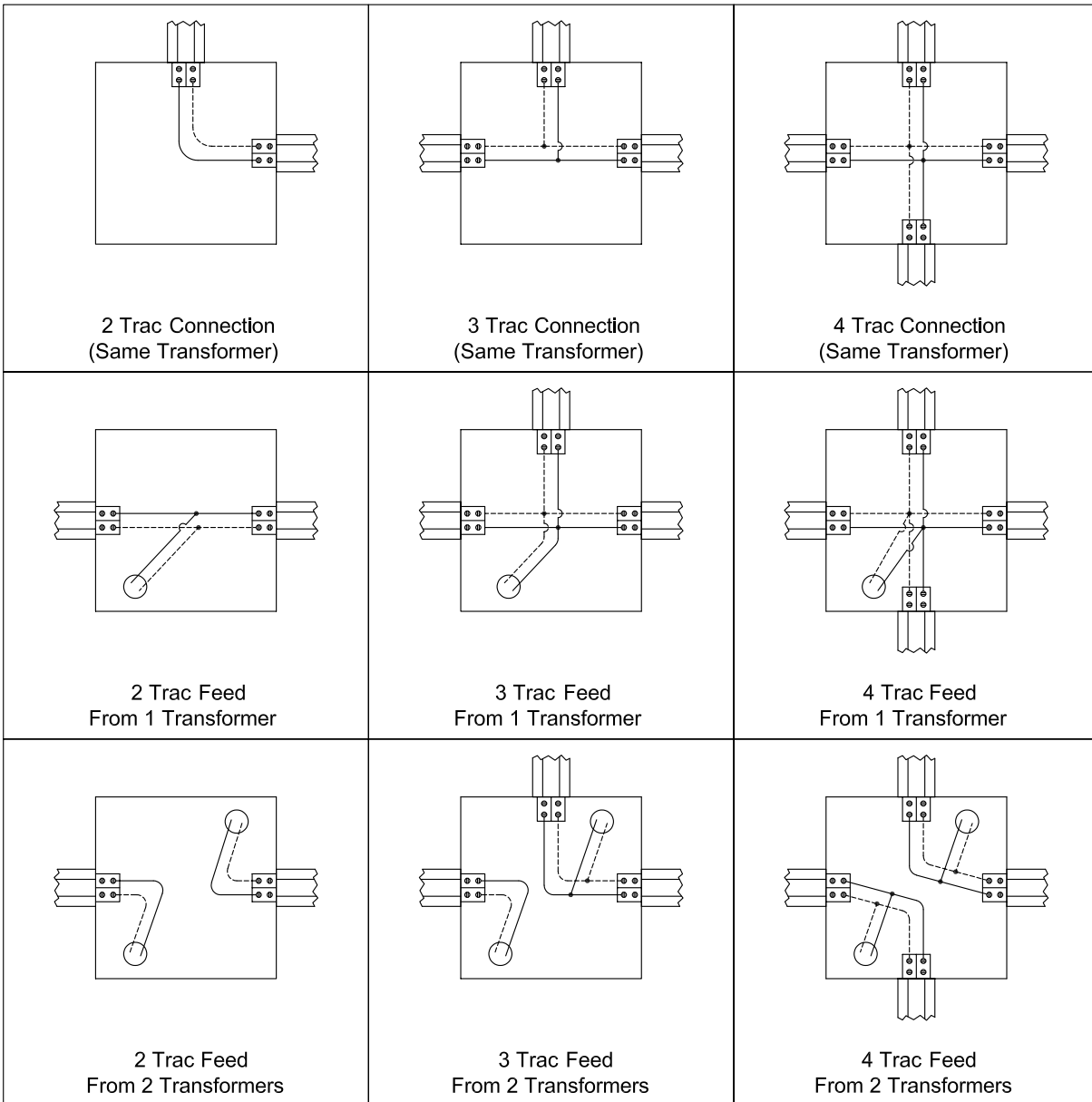

Figure 2



NOTES

- WIRES ARE SHOWN DASHED FOR CLARITY ONLY.
- TERMINAL BLOCK CANNOT HAVE MULTIPLE WIRES INSERTED INTO EACH WIRE OPENING.
- FOR ADDITIONAL WIRING CONFIGURATIONS NOT SHOWN PLEASE CONSULT FACTORY.