

JUNO TYPE MINI LED RECESSED HOUSING

MD1 – MINI DOWNLIGHTS

MG1 – MINI GIMBALS

WARNING: For your safety, read and understand instructions completely before starting installation. Before wiring to power supply or secondary devices, turn off electricity at the fuse or circuit breaker box.

Note: Juno recessed fixtures are designed to meet the latest NEC requirements and are listed in full compliance with UL 2108. Before attempting installation of any recessed lighting fixture, check your local electrical building code. This code sets the wiring standards and installation requirements for your locality and should be understood before starting work.

SAVE THESE INSTRUCTIONS

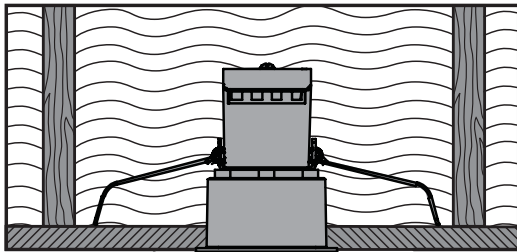

Figure 1

Juno Type IC fixtures are designed for direct contact with insulating materials which are approved for this application (Fig. 1). Fixtures may also be used in non-insulated spaces.

Note: If using MG1 Mini Gimbal in an IC application, it is recommended that the insulation be pulled away from the fixture to prevent insulation from falling into the room during fixture adjustment.

Installation Instructions

Step 1. Juno Mini Downlight & Gimbal fixtures are intended for use with any 12V AC Class 2 transformer. Note: These fixtures consume only 5W per fixture. Refer to minimum loading requirements of transformer selected to ensure proper operation of fixtures. For best performance, it is recommended that the fixture is operated with Juno TL602E electronic transformer. Make certain power delivered to fixtures does not exceed 12V AC. Follow all local & national electrical codes for wiring from the transformer to the fixtures, or from fixture to fixture if daisy-chaining (Refer to wiring diagram).

Step 2. Cut the appropriate size circular opening in mounting surface using a hole saw or other method. Recommended hole size:
 Mini Downlights – 2"
 Mini Gimbals – 2 3/8"
 Fixtures install into mounting surfaces from 1/8" to 1" thick materials.

Step 3. Route Class 2 wiring from the secondary side of the transformer through the opening in the mounting surface. Class 2 (CL2) cable or equivalent code compliant wiring is required. Strip secondary leads 5mm (.20") for insertion into fixture terminals.

Step 4. Remove terminal block cover located atop fixture (Fig. 2). Insert the two secondary leads into adjacent terminals on the right or left side of the terminal block (Fig 3). (The remaining terminals are for daisy-chain wiring if desired.) Secondary wiring is not polarized. Tighten terminal block screws securely to retain wires. (4 In-lb minimum)

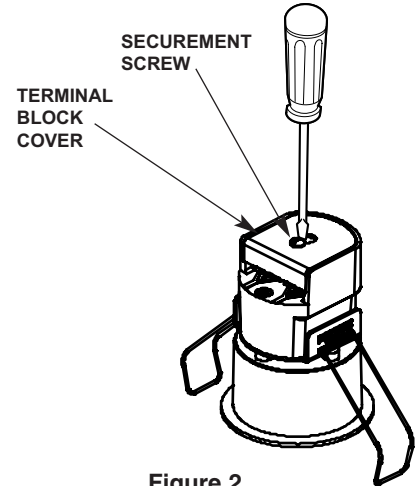

Figure 2

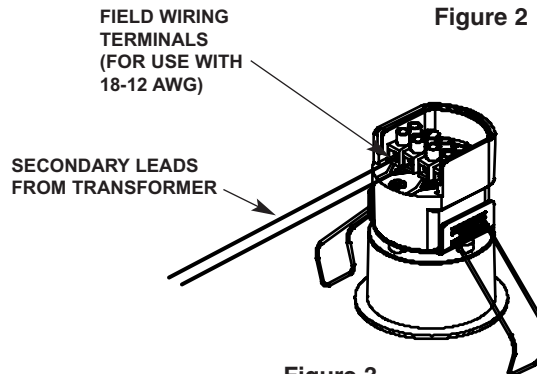

Figure 3

JUNO TYPE MINI LED RECESSED HOUSING

MD1 – MINI DOWNLIGHTS

MG1 – MINI GIMBALS

Step 5. Make certain no bare conductors are exposed after attachment to terminals. Replace terminal block cover when wiring is completed.

Step 6. Fixtures may also be daisy-chained by routing Class 2 12V AC wiring from fixture to fixture (Refer to wiring diagram). Always connect cable wires to adjacent terminals on the far right or far left side of the terminal blocks. Tighten all terminal block screws to 4 In-lb minimum.

Step 7. Push excess wire into opening in mounting surface, displace fixture coil springs as shown, (Fig. 4) insert fixture into opening. Springs will recoil to hold fixture in place. Make certain wires are contained behind the mounting surface and not damaged in any way.

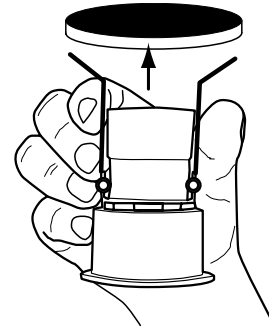
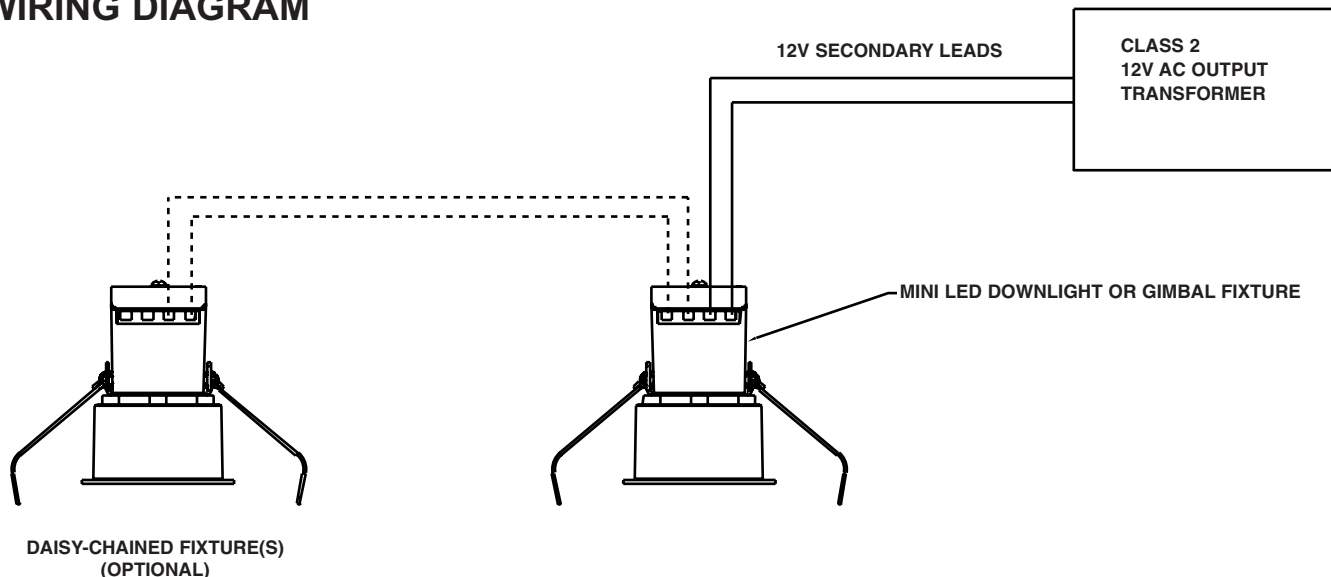

Figure 4

Step 8. Gimbal fixtures may be adjusted to direct light as desired. Remove fixture from mounting surface, adjust light aiming by rotating lower housing to desired position and re-install. Make certain wires are not twisted or damaged as a result of the re-aiming.

Step 9. Complete installation of all fixtures before restoring electrical power.

WIRING DIAGRAM



WARRANTY

Juno Lighting Group provides five year limited warranty on LED components from date of purchase. Juno Lighting Group's obligation is expressly limited to repair or replacement, without charge, at Juno Lighting Group's factory after prior written return authorization has been granted. This warranty shall not apply to products which have been altered or repaired outside of Juno Lighting Group's factory. This warranty is in lieu of all other warranties, expressed or implied, and without limiting the generality of the foregoing phrase, excludes any implied warranty of merchantability. Also, there are no warranties which extend beyond the description of the product on the company's literature setting forth terms of sale.

1300 South Wolf Road • Des Plaines, IL 60018
PHONE (847) 827-9880 • FAX (847) 827-2925 • www.junolightinggroup.com



JUNO LIGHTING GROUP
by Schneider Electric