



UFO-LED25 LED BATTERY PACK INSTALLATION INSTRUCTIONS

! IMPORTANT SAFEGUARDS !

WHEN USING ELECTRICAL EQUIPMENT, BASIC SAFETY PRECAUTIONS SHOULD ALWAYS BE FOLLOWED, INCLUDING THE FOLLOWING:

READ AND FOLLOW ALL SAFETY INSTRUCTIONS

1. To prevent high voltage from being present on the orange/black and yellow/black output leads prior to installation, inverter connector must be open. Join inverter connector after the battery pack inverter has been installed and before the AC power is supplied.
2. For use with fluorescent, incandescent or LED fixtures up to 20 W (0°C to 50°C including driver/ballast) at unity power factor. This product is also rated up to 25 W (0°C to 45°C including driver/ballast) at unity power factor.
3. Make sure all connections are in accordance with the National Electrical Code and any local regulations.
4. To reduce the risk of electric shock, disconnect both normal and auxiliary power supplies and inverter connector of the battery pack inverter before servicing.
5. This battery pack inverter is for factory or field installation.
6. An AC power source (120, or 277 VAC, 60 Hz) ahead of any wall switch is required to provide battery charging current.
7. Do not install near gas or electric heaters.
8. This product is for use with indoor or damp locations where ambient temperature is 0°C to 50°C. Not suitable for wet or hazardous locations.
9. This is a sealed unit. Integral battery is not replaceable. Replace entire unit when necessary.
10. The use of accessory equipment not recommended by the manufacturer may cause an unsafe condition.
11. Do not use this product for other than intended use.
12. Servicing should be performed by qualified service personnel.
13. Equipment should be mounted in locations and at heights where it will not be subjected to tampering by unauthorized personnel.

SAVE THESE INSTRUCTIONS



CONTAINS NICKEL-CADMIUM
RECHARGEABLE BATTERY.
MUST BE RECYCLED OR
DISPOSED OF PROPERLY.



Hubbell Lighting, Inc.

WARNING – This product contains chemicals known to the State of California to cause cancer, birth defects and/or other reproductive harm. Thoroughly wash hands after installing, handling, cleaning, or otherwise touching this product.

04/11/13

©

INSTALLATION



WARNING: TO PREVENT HIGH VOLTAGE FROM BEING PRESENT ON RED & YELLOW OUTPUT LEADS PRIOR TO INSTALLATION, BATTERY CONNECTOR MUST BE OPEN. JOIN INVERTER CONNECTOR AFTER INSTALLATION IS COMPLETE AND BEFORE AC POWER IS SUPPLIED.

NOTE: Make sure that the necessary branch circuit wiring is available. An unswitched source of power is required. The unswitched and switched power source must be fed from the same branch circuit.

INSTALLING THE BATTERY PACK INVERTER

The battery pack inverter will be located between the AC power sources and the AC ballast/driver as shown in wiring diagram section of instructions.

NOTE: The battery pack inverter may be installed in close proximity to the fixture or remote from the fixture. The maximum remote distance using 16 AWG wire is 250 ft. Contact the factory for more information.

The AC power is fed to the battery pack inverter.

The AC ballast/driver receives power from the battery pack. Identify the output wires of the battery pack inverter by the presence of the orange/black and yellow/black leads.

Step 1 - Disconnect AC power from fixture

Disconnect all power sources from lighting fixture and ensure they are locked out during installation or maintenance.

Disconnect power leads from the AC ballast/driver.

Select a suitable location for the battery pack inverter and install such that its output leads can connect to the input leads of the AC ballast/driver.

See Illustration 1, for typical installation and select appropriate mounting method.

Step 2 - Connect the Battery Pack Inverter to the proper line voltage.

Verify that the inverter connector (red and white) is disconnected. Note that the unswitched hot connects to the black input lead of the battery pack inverter.

Step 3 - Wiring the Battery Pack Inverter

Use the wiring diagram found on page 4 as reference.

Connect the AC power source leads to the input of the battery pack inverter.

Connect the output leads of battery pack inverter to the AC ballast/driver.

Wire the AC ballast/driver with the lamp in accordance with manufactures installation instructions. No ballast/driver is necessary for incandescent lamp application.

Make sure all connections are in accordance with the National Electrical Code and any local regulations.

Connect the indicator LED by matching violet and brown leads.

In a readily visible location, attach the label "CAUTION—This Unit Has More Than One Power Connection Point. To Reduce The Risk Of Electric Shock, Disconnect Both The Branch Circuit-Breakers Or Fuses And DC Power Supply (Backup Ballast Inverter Connector) Before Servicing."

Step 4 - Join the inverter connector & apply AC power

After installation is complete, join the inverter connector and apply AC power.

At this point, power should be connected to both the AC ballast and the battery pack inverter, and the Charging Indicator Light should illuminate indicating the battery is charging.

A short-term discharge test may be conducted after the battery pack inverter has been charging for 1 hour. Charge for 24 hours before conducting a long-term discharge test. Refer to OPERATION.

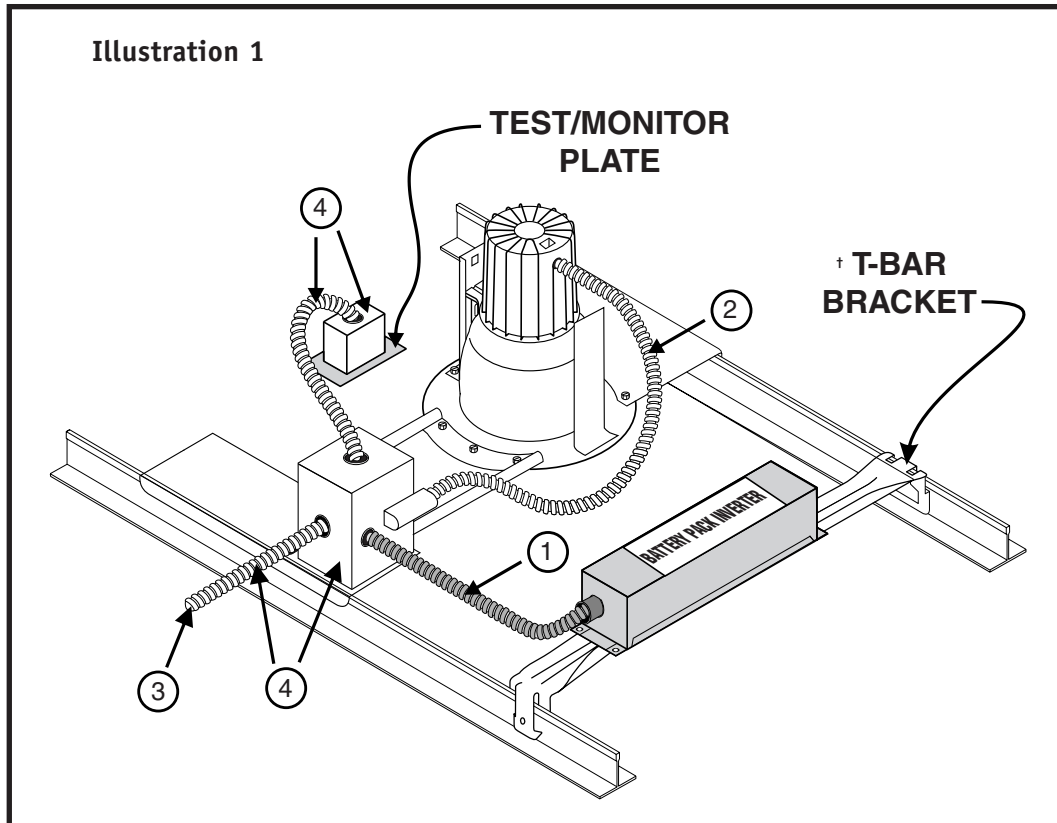

 Battery Pack Inverter  No Shading - Equipment supplied by others

- 1 - Flexible conduit (supplied) to connect ballast wires.
- 2 - Existing conduit to run existing wires to lamp holder.
- 3 - AC line in.
- 4 - Conduit and junction box (not supplied).

OPERATION

During normal operation, AC power is supplied to the AC ballast/driver through the battery pack and the inverter charges the battery. Connecting the inverter connector wires (red and white) enables the emergency circuit and supplies power to the control/monitor circuit. The battery pack inverter detects AC input line voltage (120/277) and automatically sets the output voltage during emergency mode.

When AC power fails, the battery pack inverter automatically switches to emergency mode, keeping the load illuminated for a minimum of 90 minutes. When AC power is restored, the battery pack inverter returns to charging mode. The battery pack inverter consists of a low-battery voltage disconnect which is reset when AC power is restored. The unit can also detect an abnormal load condition (open or shorted load) during emergency mode operation and will protect the inverter from damage.

MAINTENANCE

Although no routine maintenance is required to keep the battery pack inverter functional, it should be checked periodically to ensure that it is working. The following schedule is recommended:

1. Visually inspect the charging indicator light monthly. It should be illuminated.
2. Test the emergency operation of the fixture at 30-day intervals for a minimum of 30 seconds. The lamp should operate at full illumination.
3. Conduct a 90-minute discharge test once a year. The lamp should operate at full illumination for at least 90 minutes.

REFER ANY SERVICING INDICATED BY THESE CHECKS TO QUALIFIED PERSONNEL.

BATTERY PACK INVERTER AND AC BALLAST/DRIVER MUST BE FED FROM THE SAME BRANCH CIRCUIT
TYPICAL SCHEMATICS ONLY. CONSULT THE FACTORY FOR OTHER WIRING DIAGRAMS.

WIRING DIAGRAM

