

RAB LIGHTING

QF200FW



JOB NAME: _____
 DATE: _____
 TYPE: _____

DESCRIPTION

The Mini Curve. High quality die cast flood with rounded back and integral glare shield. Tempered glass lens.

SPECIFICATIONS

Finish:

Chip and fade resistant polyester powder coating

Housing:

Die cast aluminum, 1/2" NPS threaded arm with locking swivel fits all standard mounting covers.

Lens Gasket:

High temperature silicone gasket stays in place during relamping

Lens:

Thermal, tempered, shock resistant glass

Reflector:

Semi-specular anodized aluminum

Sockets:

Porcelain RSC base sockets with gold plated spring loaded contacts and strain relieved 250° C Teflon insulated wires

UL Listing:

Suitable for wet locations. Suitable for mounting within 4' of the ground

Patents:

RAB sensor and fixture designs are protected under U.S. and International Intellectual Property laws

Color:

White

Weight:

1.85

DIMENSIONS

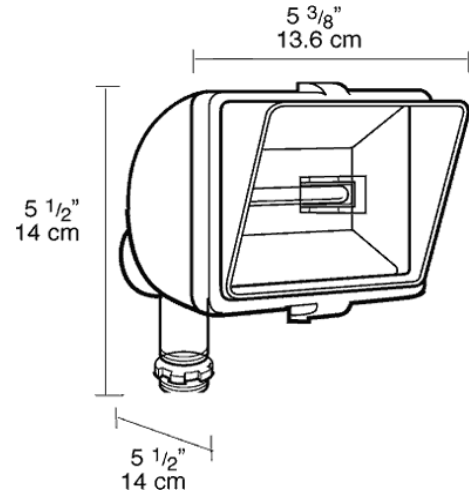

PHOTOMETRIC

500w Quartz @ 15' Mounting Height
 Aimed 30° below horizontal

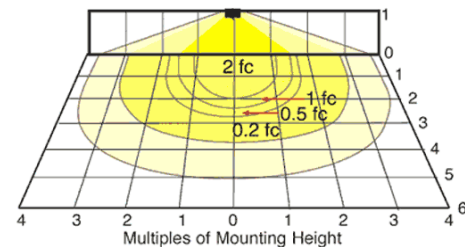

Mounting Height	Multiplier	Watts	Multiplier
8'	3.5	500	1.0
12'	1.6	300	.6
15'	1.0	200	.3
20'	.6		
24'	.4		

ORDERING INFORMATION

Double Ended Quartz Halogen
 Lamp supplied with fixture

Total Watts	Lamp Type	Lamp Base	Ballast
200	T3	Double Ended	0

Starting Amps/ Operating Amps

120V	208V	240V	277V
0	0	0	0

Input Watts LAMP Initial Lamp

Watts	ANSI	Lumens	Hours
200	0	3600	2000

Factory Installed Options
 Add suffix to Catalog Number

Note: Specifications may change without notice

RAB Lighting, Inc. • 170 Ludlow Ave • Northvale, NJ 07647 • Tel: 888 RAB-1000 • Fax: 888 RAB-1232 • www.rabweb.com
 © 2009