



Bullet shape die cast aluminum flood with 13 Watt LED Light Engine. Comes with narrow spotlight reflector installed.

Color: Verde green

Weight: 4.8 lbs

| | |
|---------------------|--------------|
| Project: | Type: |
| Prepared By: | Date: |

| Driver Info | | LED Info | |
|--------------|------------------|-----------------|--------------|
| Type: | Constant Current | Watts: | 13W |
| 120V: | 0.12A | Color Temp: | 5000K (Cool) |
| 208V: | 0.09A | Color Accuracy: | 67 CRI |
| 240V: | 0.08A | L70 Lifespan: | 100,000 |
| 277V: | 0.07A | Lumens: | 1,315 |
| Input Watts: | 14W | Efficacy: | 92 LPW |
| Efficiency: | 91% | | |

Technical Specifications

Listings

UL Listing:

Suitable for wet locations. Suitable for ground mounting.

DLC Listed:

This product is on the Design Lights Consortium (DLC) Qualified Products List and is eligible for rebates from DLC Member Utilities.

IESNA LM-79 & LM-80 Testing:

RAB LED luminaires have been tested by an independent laboratory in accordance with IESNA LM-79 and LM-80, and have received the Department of Energy "Lighting Facts" label.

Electrical

Driver:

Multi-chip 13W high output long life LED Driver Constant Current, 100V - 277V, 50/60 Hz.

THD:

9.9% at 120V

Power Factor:

98.5% at 120V

Optical

NEMA Type:

2H x 2V Beam Spread.

LED Characteristics

LEDs:

Multi-chip, high-output, long-life LEDs

Color Stability:

RAB LEDs exceed industry standards for chromatic stability.

Color Uniformity:

RAB's range of CCT (Correlated Color Temperature) follows the guidelines of the American National Standard for Specifications for the Chromaticity of Solid State Lighting (SSL) Products, ANSI C78.377-2011.

Construction

Cold Weather Starting:

Minimum starting temperature is -40°F/-40°C

Thermal Management:

Superior heat sinking with external Air-Flow fins

Housing:

Precision die-cast aluminum housing, lens frame and mounting arm.

Reflector:

Semi-specular, vacuum-metalized polycarbonate

Mounting:

Heavy-duty mounting arm with "O" ring seal & stainless steel screws.

Gaskets:

High-temperature silicone gaskets

Finish:

Our environmentally friendly polyester powder coatings are formulated for high-durability and long-lasting color, and contain no VOC or toxic heavy metals.

Green Technology:

Mercury and UV free, and RoHS compliant. Polyester powder coat finish formulated without the use of VOC or toxic heavy metals.

Other

Country of Origin:

Designed by RAB in New Jersey and assembled in the USA by RAB's IBEW Local 3 workers.

Buy American Act Compliant:

This product is a COTS item manufactured in the United States, and is compliant with the Buy American Act.

Recovery Act (ARRA) Compliant:

This product complies with the 52.225-21 "Required Use of American Iron, Steel, and Manufactured Goods-- Buy American Act-- Construction Materials (October 2010).

Trade Agreements Act Compliant:

This product is a COTS item manufactured in the United States, and is compliant with the Trade Agreements Act.

GSA Schedule:

Suitable in accordance with FAR Subpart 25.4.

HNLED13VG

Dimensions

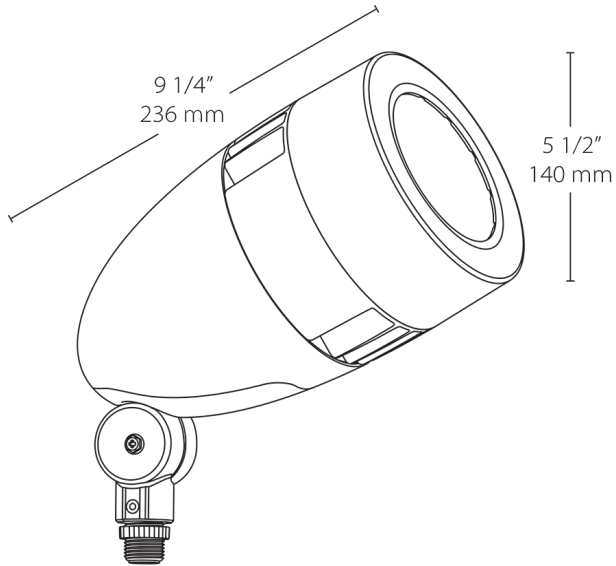

Features

- 80% energy savings vs. PAR floods
- Mount on junction box or on RAB Mighty Post
- Patent-pending Air-Flow technology
- 5-year warranty