

JUNO® T5HO Cable Mount Installation Instructions

CAUTION: To reduce risk of fire and electrical shock, use only with JUNO "R", "T", "TU", "TT", and "V" series trac.

All Juno trac sections have an embossed line that indicates the trac polarity. All Juno Trac fixture adapters have raised arrows that must point to the polarity line on the trac section when they are installed.

Fixture Installation

Caution: Make sure power is OFF. Do not install fixtures into a trac section that is energized.

1. For 2-circuit line voltage trac, lift positive contact (marked "P") with slotted screwdriver until it is raised into position of second circuit. Install plastic support under the contact (provided with fixture).
2. Insert the powered side (side with switch) of trac adapter into trac channel first.
3. Rotate adapter 1/4 turn (90 degrees) so that the polarity arrows point towards the polarity line on the trac. Refer to Figure One.
4. Repeat this process with the non-powered side of the fixture, making sure that the polarity arrows point towards the polarity line of the trac.
5. Turn power ON and then fixture switch to ON.

Note: To uninstall fixture, pull the tab with arrows on it (on adapter) down, and then turn.

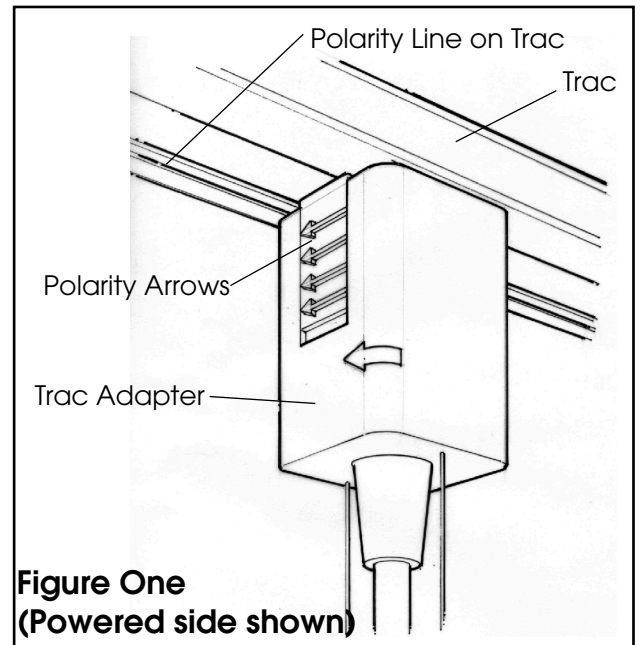

Figure One
(Powered side shown)

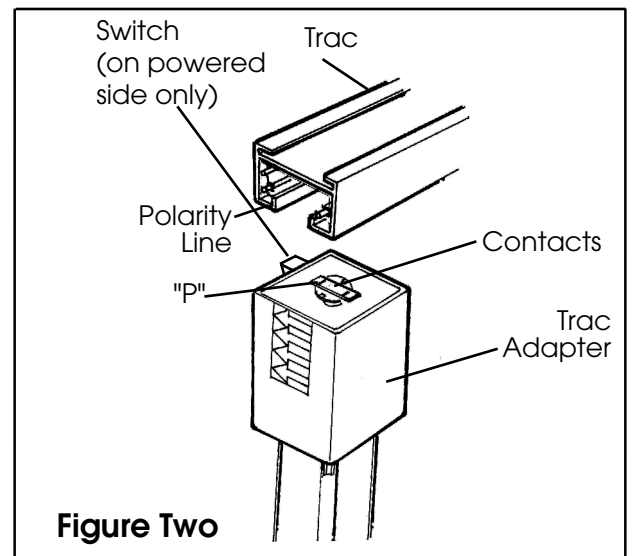
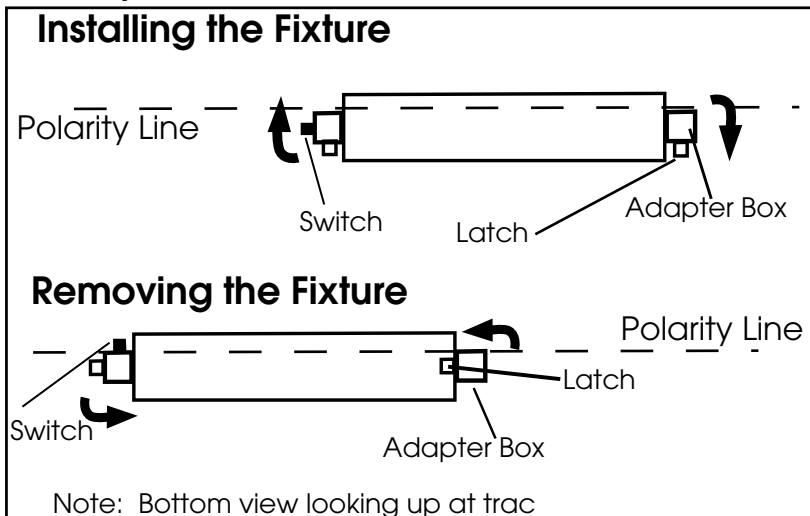

Figure Two



Adjusting the Height of the Fixture's Cables

1. Remove the knob cover (round metal cover on each end of the housing) from the fixture using a phillips screwdriver. To raise the fixture, pull the cable down through the cable glide to the desired height, being sure to level the fixture. See Figure Three for details. Repeat on the other side. To lower the fixture, press down on the top of the cable glide and pull the cable up through the cable glide to desired length, once again being sure to level the fixture. Refer to Figure Four.

2. Once the desired length is reached, wrap the excess cable around the two "ears" on the inside of the knob base. Place the end of the wire cable into the notch as shown in Figure Five.

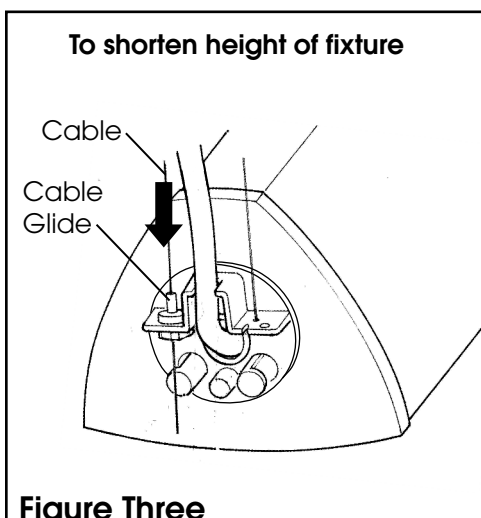

Figure Three

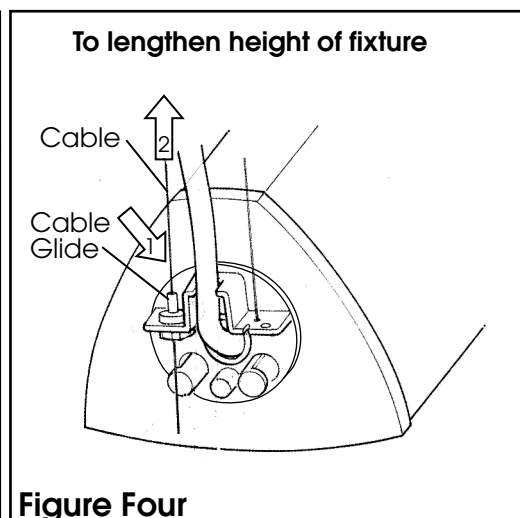

Figure Four

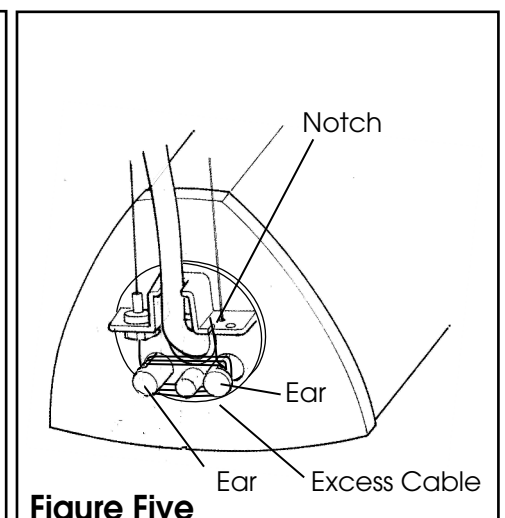

Figure Five

Adjusting the Length of the Fixture's Electrical Cord

1. Remove the screws of the access panel as shown in Figure Six.
2. Once inside the housing, remove the strain relief (using a flathead screwdriver) and remove the wire nuts from the end of the electrical cord. Refer to Figure Seven.
3. Pull the cord to length and cut it. Retighten the strain relief being sure that the electrical cord is crimped down tightly.
4. Strip and terminate the color coded wires.
5. Replace the access panel. It should fit into the grooves in the housing and in alignment with the existing panel as shown in Figure Six.

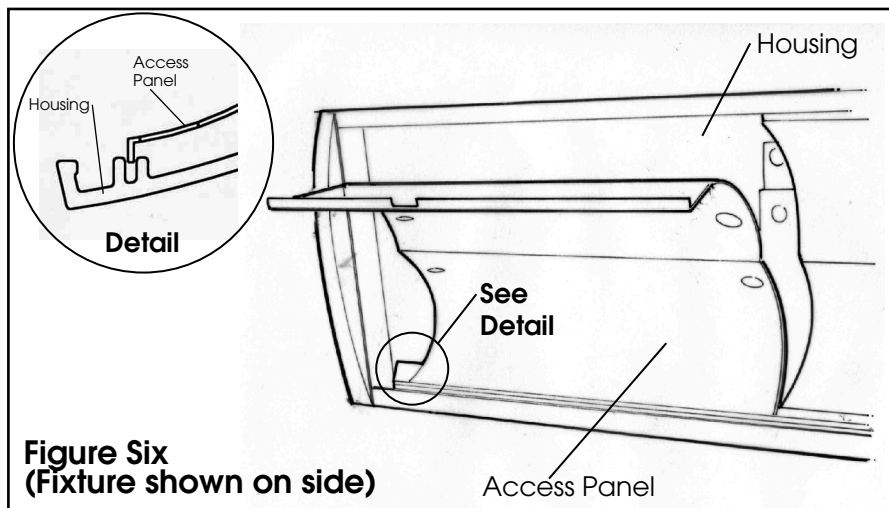

Figure Six
(Fixture shown on side)

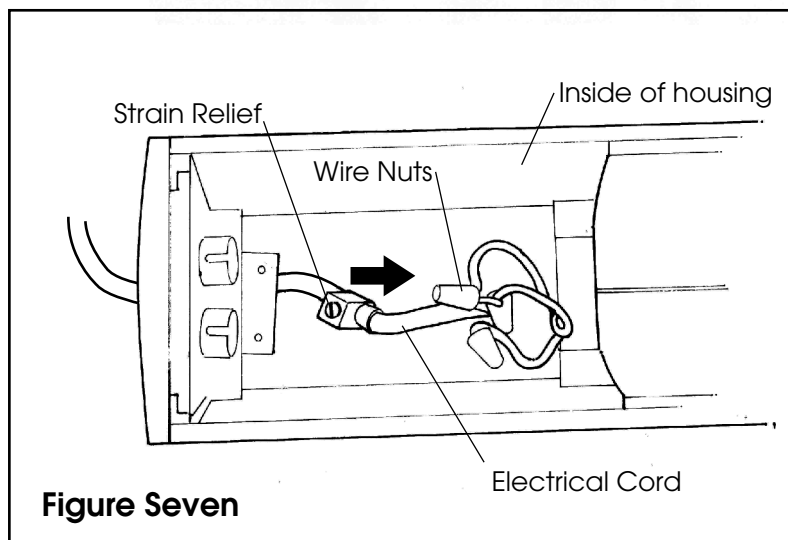

Figure Seven

Lamping Instructions

1. Remove louver by pinching spring tabs in as shown in Figure Eight. Install appropriate lamp according to chart below:

2' version	2-24 watt T5HO lamps
3' version	2-39 watt T5HO lamps
4' version	2-54 watt T5HO lamps

Rotate lamp in the socket until it stops to secure it in place, then replace cover.

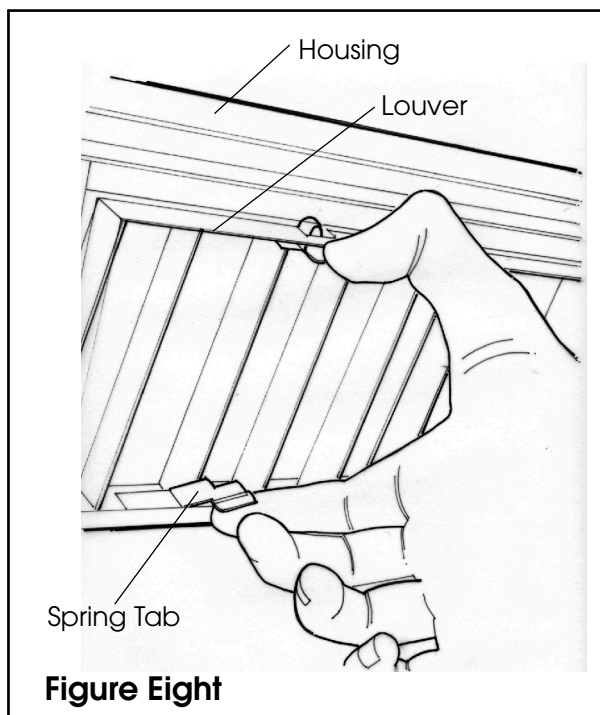

Figure Eight

Installing the Lens (ordered separately)

1. To install the lens, remove the louver (Figure Eight) and place the lens over both of the lamps. Secure into place by rotating the latch on the fixture housing over the lens as shown in Figure Nine. Repeat for opposite side, then replace louver.

Lens catalog #s: T5C22 2' Version
T5C32 3' Version
T5C42 4' Version

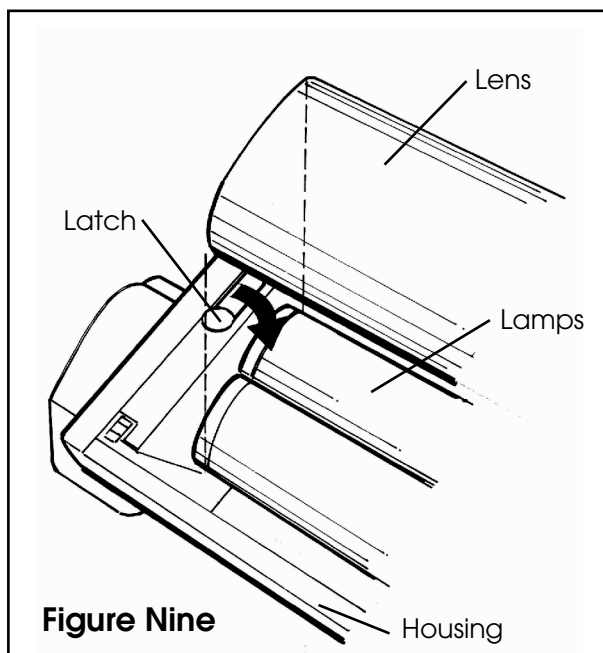

Figure Nine

WARRANTY

Juno warrants that its products are free from defects in material and workmanship. Juno's obligation is expressly limited to repair or replacement, without charge, at Juno's factory after prior written return authorization has been granted. This warranty shall not apply to products which have been altered or repaired outside of Juno's factory. This warranty is in lieu of all other warranties, expressed or implied, and without limiting the generality of the foregoing phrase, excludes any implied warranty of merchantability. Also, there are no warranties which extend beyond the description of the product on the company's literature setting forth terms of sale. Product Services phone # (888) 387-2212